



Directional Control Air Valves & Accessories

Keeping the world
moving and working.

 **ALKON**
CORPORATION



 **ALKON**
CORPORATION

Keeping the world
moving and working.

ENTREPRENEURIAL
CAPABLE
GLOBAL
CAN-DO
WORLD CLASS

At Alkon, we are committed to providing quality products for our customers' needs. Our valves can be found in applications as varied as eighteen-wheelers to amusement park rides. Why? Because our precision engineering, innovative manufacturing, and dedicated service convince our customers that at Alkon, we get it right.

ABOUT US The personal touch of a small company drives our world-class manufacturing operation. For our employees, meeting customer needs is the primary concern. We take the time to understand each job and client. We take the opportunity to provide each customer with products of superior quality and value. We take pride that strong relationships and outstanding products result in continued customer satisfaction. **Service. Satisfaction. Success.** This is Alkon's philosophy.

HISTORY Alkon Corporation began in Hawthorne, New Jersey as a start-up company, carrying a single line. Since its creation in 1950, the company, and its product line, has grown steadily. In 1999, the corporate headquarters moved to our current 70,000 square feet facility in Fremont, Ohio. Our line has expanded to include a wide variety of fittings, valves, and flow controls. An additional manufacturing facility in Mexico, Alkon-Mexico, partners with us in production of forgings and primary machining.

We are a privately held company. Many of our employees — from executives to shop employees — are shareholders. We are active in Alkon's growth and invested in Alkon's success.





QUALITY PLEDGE

Alkon Corporation is committed to robust quality and service through continuous improvement, innovative design, dependable delivery, and an emphasis on customer relations.



WARRANTY

Alkon Corporation warrants its products to be free of defects in material and workmanship when properly installed and maintained. No other warranty is implied or expressed. Alkon Corporation's liability for remedy is limited to replacement or repair at Alkon's sole discretion if the parts are returned under a valid RGA to us within 180 days of purchase. No allowance whatsoever will be made for repairs made by the purchaser nor will Alkon be liable for consequential or other damages or any expense incurred through the use of its products. The warranty is valid solely on products of current design.

Alkon Corporation is constantly upgrading its products. In keeping with this policy, Alkon Corporation reserves the right to change dimensions, designs and/or performance. These changes may be made at any time.

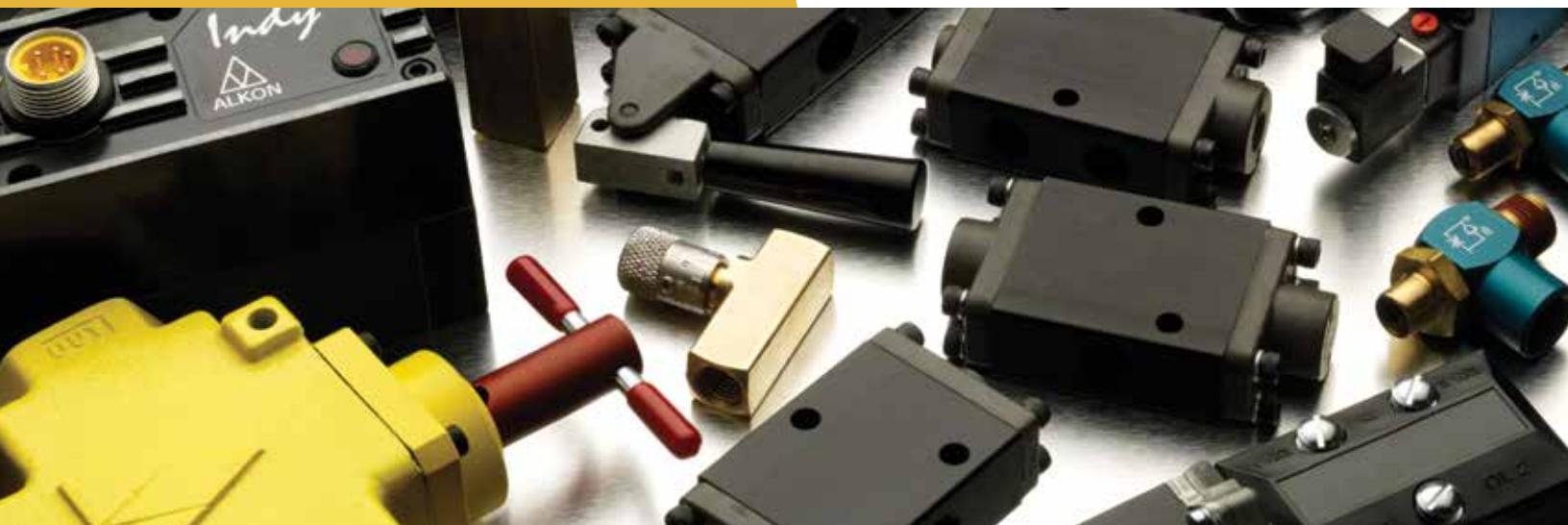

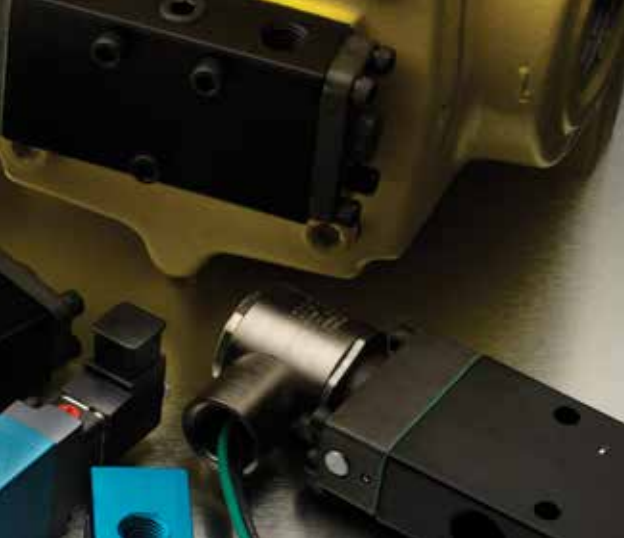

CAPABILITIES

Alkon's history — over fifty years of expertise in the valves industry — positions us to provide a vast array of services to our clients. From our role as a major U.S. manufacturer of brass push-to-connect (PTC) fittings, to our unique technologies for producing lapped spool valves, Alkon supplies what our clients need, when they need it.

Alkon's focus is to provide a quality product with an innovative design. We have the expertise and the technology to produce custom valves, from the design stage, through engineering to manufacturing. Unlike many of our competitors, we apply our own thread seal. Sealant material quality, and that of all incoming materials, must meet our high standards.

Alkon's state-of-the-art manufacturing facility can handle a variety of runs and processes to ensure that orders, no matter what size are met, and that processes are done with quality and care. We monitor inventory carefully, so that components are always available and changes in orders are accurate. Our custom storage units guarantee that orders are assembled efficiently and shipped on time.



Directional Control Air Valves & Accessories

Alkon valves are some of the fastest cycling and most reliable in the industry. We specialize in directional control air valves and valves specially designed for the transportation industry. We offer hundreds of options for one of the most complete valve product lines in the industry. So, every valve is made to order with ONLY the options you need. And with 100% product testing, we can guarantee performance.

TABLE OF CONTENTS

| | |
|---|----|
| SERIES P VALVES | 7 |
| LAPPED SPOOL VALVES | 7 |
| SERIES P-MC 3-WAY VALVES..... | 8 |
| SERIES P-035 4-WAY VALVES | 9 |
| SERIES P-070 / P-140 4-WAY VALVES | 10 |
| SERIES P - 4-WAY VALVES | 11 |
| VALVE ACCESSORIES | 12 |
| OMNI SERIES VALVES | 13 |
| OMNI 150 SERIES VALVES | 17 |
| OMNI 250 SERIES VALVES | 20 |
| OMNI 375 SERIES VALVES | 27 |
| STAINLESS STEEL 316 SERIES..... | 42 |



CONTACT US

Alkon Corporation Corporate Headquarters

USA Head Office

728 Graham Drive
Fremont, OH 43420

P: 419-333-7000
F: 419-355-9211

Alkon Products, S.A. de C.V.

Mexico Head Office

Destajistas No. 20
Parque Industrial Xhala
Cuautitlan Izcalli EDO. DE MEX.
C.P. 54730

P: 872-46-97
P: 872-58-09
F: 872-31-62

www.alkoncorp.com

sales@alkoncorp.com

LAPPED SPOOL VALVES

The heart of the Series P valve is the packless body and spool assembly constructed of aluminum with a ceramic hard aluminum oxide finish. This unique cartridge and spool assembly is completely isolated from external forces; is pressure balanced, allowing any port to be pressurized or subjected to back pressure with no effect on shifting force, and has been designed to meet the most stringent requirements that today's customers demand. All Series P valves are in-line, and all can be manifolded. This series is manufactured to the highest quality standards in the industry today and all carry a three year warranty on all parts of the valve, including the coil. No lubrication; extremely fast shifting coupled with very low minimum pilot pressure, a variety of options and all at a low cost.



Series P Spool Assembly

FILTRATION:

A 40 micron filter is recommended.

OPERATING PRESSURES:

- Internal Pilot (Standard): 10 P.S.I. to 150 P.S.I.
- External Pilot: Vacuum to 150 P.S.I.

NOTE: External Pilot Supply of at least 10 P.S.I. required for vacuum service.

MOUNTING:

All Series P Valves have no limitations as far as the orientation of the valve. Coils can be rotated in any direction for ease of installation.

CYCLE RATE:

Series P Valves may be cycled at over 2000 cycles per minute in most applications.

OPTIONS:

Include hard wired coils; factory assembly of valves to manifolds; a variety of plug connectors; pre-installed AQ push-in fittings, and many other popular options.

WARRANTY:

Series P valves are covered by a three year warranty from date of purchase. All provisions of our standard warranty policy (available upon request) apply.



Series P Valves

CONSTRUCTION:

- Body, End Caps & Manifolds: Anodized Aluminum
- Cartridge & Spool: Hard Coated Aluminum
- Coils: Molded Nylon
- O-Rings: Buna N (Nitrile)

LUBRICATION:

NONE REQUIRED — However a general purpose lubricating oil may be used if desired. In these cases, we recommend ASTM/ISO viscosity Grade.

SERIES P-MC 3-WAY VALVES

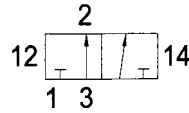

P-MC 3-Way Valve

GENERAL INFORMATION:

- Compact size
- Variety of combinations
- In line design - or mount on manifold
- Normally open or normally closed models
- 1/8 NPT or 1/4 NPT ports
- Cv - .5 (1/8") or .85 (1/4")
- Cycle Rate - Up to 2,500 per minute
- Standard locking manual override

MANIFOLDS:

- Available from 2 to 10 stations
- P-MC1: Part # 22029 - (# of stations)
- P-MC2: Part # 22046 - (# of stations)

BLOCKING PLATE:

- To block off manifold station
- P-MC1: Part # 22060
- P-MC2: Part # 22061

LOW WATTAGE SOLENOID:

Consult factory

SURGE SUPPRESSORS:

Consult factory

CONNECTORS:

- Part # 21876: Standard Connector
- Part # 21878: Standard Connector with pre-wired 3 ft. leads
- Part # 21905 - (): Lighted Connector (Voltage)
- Part # 21906 - (): Lighted Connector (Voltage) with pre-wired 3 ft. leads
- Part # 22076: Standard Connector with pre-wired 6 ft. leads

SIMPLE HOW-TO-ORDER INSTRUCTIONS:

| P-M SERIES | C TYPE | 1 SIZE | SS FUNCTION | 115/60 VOLTAGE | | HW OPTIONS |
|------------|---------|-------------|----------------------|----------------|--------|------------------------------------|
| P | MC (NC) | 1 (1/8 NPT) | SS - Single Solenoid | 6 VDC | 24/60 | HW - Hard Wire Coil Leads |
| | MO (NO) | 2 (1/4 NPT) | SP - Single Pilot | 12 VDC | 115/60 | FA - Factory Assembly of Manifolds |
| | | | | 24 VDC | 230/60 | XP - External Pilot Supply Port |

DIMENSIONS:

| MODEL # | A | B | C | D | E | F | G | H | J | K | L |
|---------|------|------|-------|------|------|------|-------|------|------|------|-----|
| P-MC1 | .961 | 4.25 | 1.188 | 1.56 | .961 | .500 | 1.75 | .750 | .218 | .266 | 1/8 |
| P-MC2 | .961 | 4.25 | 1.375 | 1.88 | .961 | .500 | 1.875 | 1.00 | .200 | .400 | 1/4 |

MANIFOLDS:

| MODEL # | A | B | C | D | E | F | G | H | J |
|---------|------|-------|-------|------|------|------|------|------|-----|
| P-MC1 | .875 | .812 | 2.562 | .200 | .812 | 2.00 | .415 | 1.00 | 1/4 |
| P-MC2 | .968 | 1.063 | 3.00 | .188 | .812 | 2.00 | .415 | 1.00 | 1/4 |

USE FOLLOWING VOLTAGE CODES:

For lighted connectors

| | | |
|------------|-------------|-------------|
| 6 VDC - 01 | 12 VDC - 02 | 24 VDC - 03 |
| 24/60 - 05 | 115/60 - 06 | 230/60 - 07 |

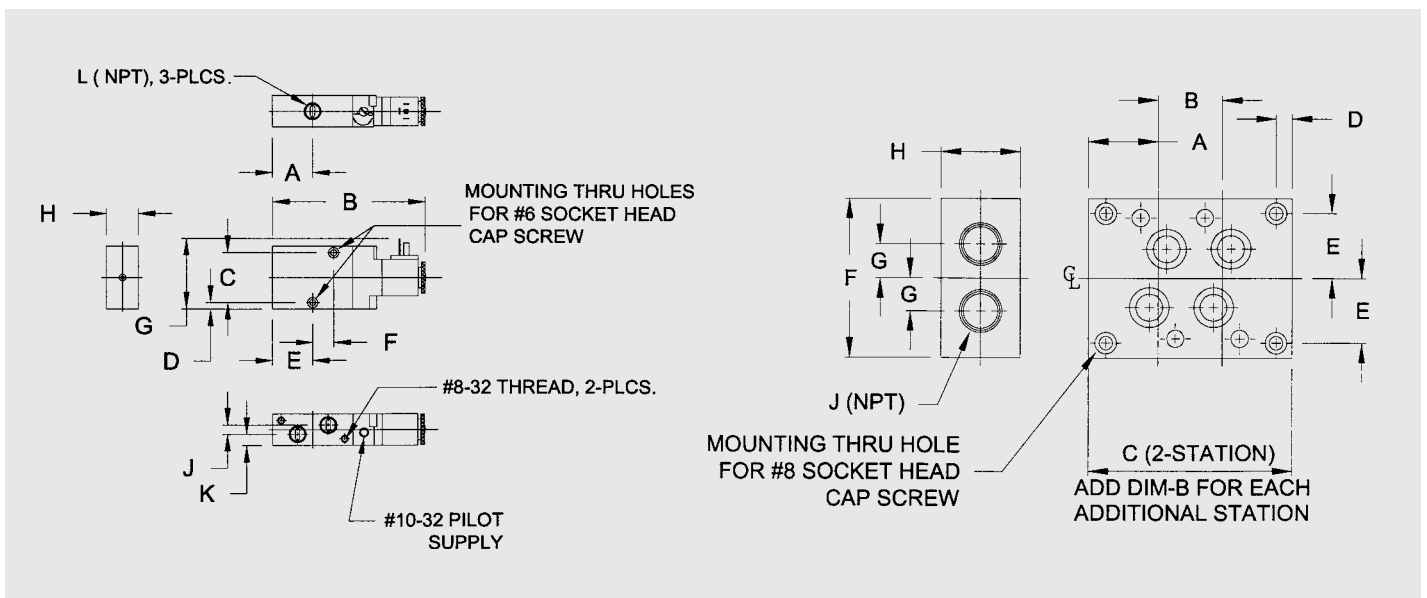

SERIES P VALVES

SERIES P-035 4-WAY VALVES

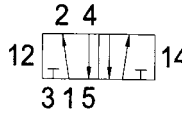

P-035 4-Way Valve

GENERAL INFORMATION:

- Compact size - Only 3/4" wide
- Multi purpose - use as a 4-Way or 3-Way
- In-line design - or mount on manifold
- Variety of models - solenoid or pilots
- 1/8 NPT Ports
- Cv - .40
- Cycle rate - Up to 2,500 per minute
- Standard locking manual overdrive

SIMPLE HOW-TO-ORDER INSTRUCTIONS:

| P-SERIES | 035 MODEL | SS FUNCTION | 115/60 VOLTAGE | | HW OPTIONS |
|----------|-----------|------------------------------------|----------------|--------|------------------------------------|
| P | 035 | SS (Single Solenoid) | 6 VDC | 24/60 | HW – Hard Wire Coil Leads |
| | | DS (Double Solenoid) | 12 VDC | 115/60 | FA – Factory Assembly of Manifolds |
| | | SP (Single Pilot) | 24 VDC | 230/60 | XP – External Pilot Supply Port |
| | | DP (Double Pilot) | | | |
| | | 3S (3 POS., DS, all ports blocked) | | | |
| | | 3P (3 POS, DP, all ports blocked) | | | |

MANIFOLDS:

Available from 2 to 10 stations
Part # 21904 - (# of stations)

BLOCKING PLATE:

To block off manifold station
Part # 21908

INTERFACE PLATE:

For mounting a P-035 to a P-070 manifold -
Part # 21910

CONNECTORS:

- Part # 21876: Standard Connector
- Part # 21878: Standard Connector with pre-wired 3 ft. leads
- Part # 21905 - (): Lighted Connector (Voltage)
- Part # 21906 - (): Lighted Connector (Voltage) with pre-wired 3 ft. leads
- Part # 22076: Standard Connector with pre-wired 6 ft. leads

LOW WATTAGE SOLENOID:

Consult factory

SURGE SUPPRESSORS:

Consult factory

USE FOLLOWING VOLTAGE CODES:

For lighted connectors

| | | |
|------------|-------------|-------------|
| 6 VDC - 01 | 12 VDC - 02 | 24 VDC - 03 |
| 24/60 - 05 | 115/60 - 06 | 230/60 - 07 |

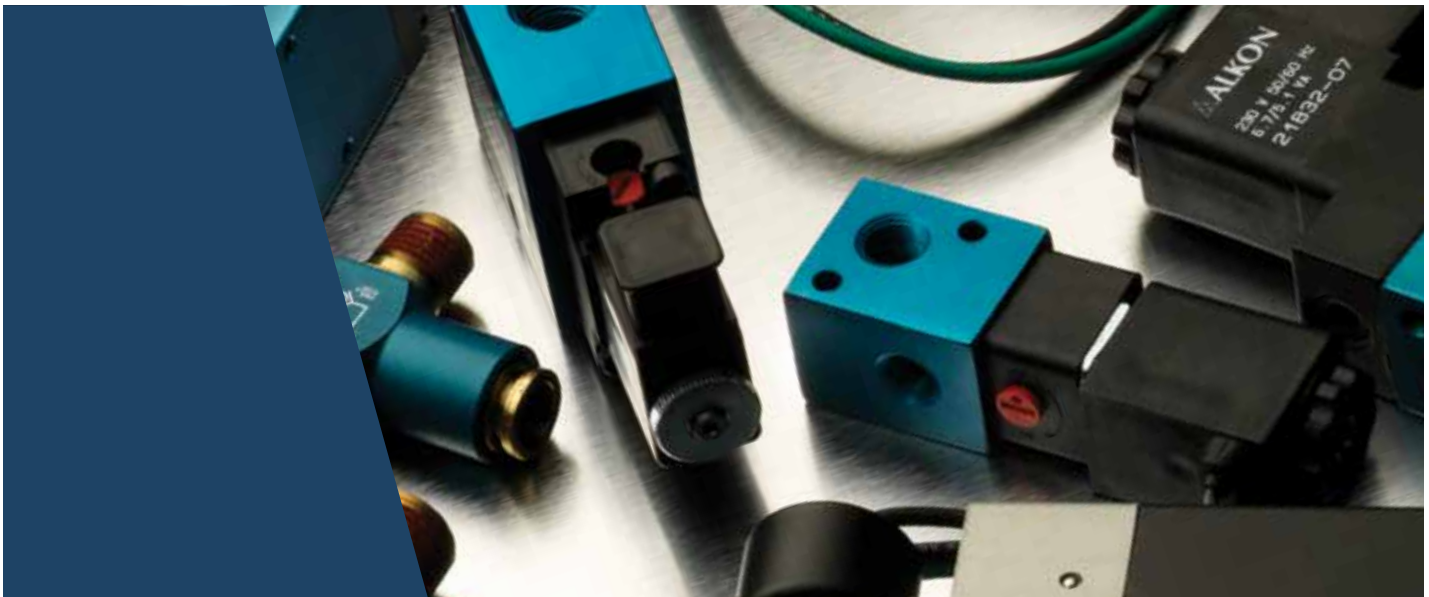

Directional Control Air Valves & Accessories

SERIES P VALVES

SERIES P-070 / P-140 4-WAY VALVES

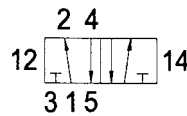

GENERAL INFORMATION:

- High flow Multi-Purpose Design
- Use as a 3-Way by plugging one port
- In line design - or mount on manifold
- Single or double solenoid or pilot
- Two or three position models available
- P-070: 1/4" Ports Cv - .8
- P-140: 3/8" Ports Cv - 1.5
- Cycle Rate - over 2,000 per minute
- Standard non-locking manual override
- Wide variety of popular options

P-070 4-Way Valve

SIMPLE HOW-TO-ORDER INSTRUCTIONS

| P-SERIES | 070 MODEL | SS FUNCTION | 115/60 VOLTAGE | | HW OPTIONS |
|----------|-----------|------------------------------------|----------------|--------|------------------------------------|
| P | 070 | SS (Single Solenoid) | 6 VDC | 24/60 | HW - Hard Wire Coil Leads |
| | 140 | DS (Double Solenoid) | 12 VDC | 115/60 | FA - Factory Assembly of Manifolds |
| | | SP (Single Pilot) | 24 VDC | 230/60 | XP - External Pilot Supply Port |
| | | DP (Double Pilot) | | | LM - Locking Manual Override |
| | | 3S (3 POS., DS, all ports blocked) | | | N4 - NEMA 4 Operator |
| | | 3P (3 POS., DP all ports blocked) | | | |

Consult factory for other available combinations

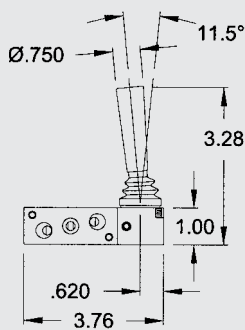

P-070 Hand Lever Valve

Part # P-070-HL

The P-070 is available in a Hand Lever Version that is compact and versatile. The standard is a spring return model that may be converted to a detented model simply by turning two Allen screws in the end cap.

MANIFOLDS:

- Available from 2 to 10 stations
- P-070: Part # 21821 - (# of stations)
- P-140: Part # 21907 - (# of stations)

BLOCKING PLATE:

- To block off manifold station
- P-070: Part # 21822
- P-140: Part # 21909

SURGE SUPPRESSORS:

Consult factory

CONNECTORS:

- Part # 21823: Standard Connector
- Part # 21839: Standard Connector with pre-wired 18" leads
- Part # 21824 - (): Lighted Connector (Voltage)
- Part # 21840 - (): Lighted Connector (Voltage) with pre-wired 3 ft. leads
- Part # 21852: 1/2 NPT Conduit Connector
- Part # 21841 - (): Connector (Voltage) with molded 3 ft. leads
- Part # 21842 - (): Lighted Connector (Voltage) with molded 3 ft. leads
- Part # 22078: Standard Connector with pre-wired 6 ft. leads

USE FOLLOWING VOLTAGE CODES:

For lighted connectors

| | | |
|------------|-------------|-------------|
| 6 VDC - 01 | 12 VDC - 02 | 24 VDC - 03 |
| 24/60 - 05 | 115/60 - 06 | 230/60 - 07 |



SERIES P VALVES

SERIES P - 4-WAY VALVES

MANIFOLD ASSEMBLY:

Manifolds can be purchased separately or valves can be assembled to them at the factory.

Hardened mounting pins (2) are screwed into the valve body (5) until flush, and then the valve unit is inserted into the manifold block (4) after positioning the O-rings (1). By tightening the Allen head screws (3), the valves are seated and connected to the manifold block. This unique method assures a leak proof assembly. When manifolds are purchased separately, each kit contains mounting pins, set screws and O-rings for the purchased number of stations.

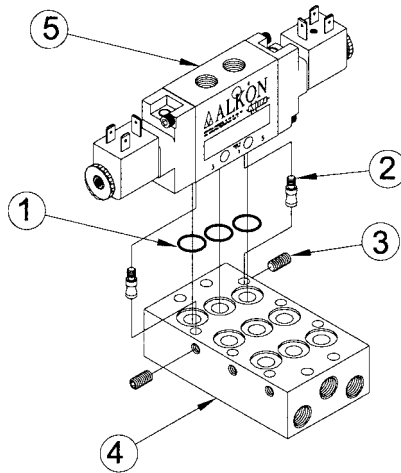

RESPONSE

| MODEL TYPE | TIME TO ENERGIZE | TIME TO DE-ENERGIZE |
|------------|------------------|---------------------|
| A.C. SOL. | 7 MS | 18 MS |
| D.C. SOL. | 10 MS | 18 MS |
| PILOT | 6 MS | N/A |

ELECTRICAL CHARACTERISTICS

| VOLTAGE | INRUSH (AMPS) | HOLDING (AMPS) | NOMINAL POWER CONSUMPTION |
|---------|---------------|----------------|---------------------------|
| 6VDC | .240 | .240 | 2.9W |
| 12VDC | .240 | .240 | 2.9W |
| 24VDC | .108 | .108 | 2.6W |
| 24/60 | .340 | .210 | 3.8W |
| 115/60 | .070 | .044 | 3.8W |
| 230/60 | .040 | .024 | 3.8W |

REPLACEMENT COILS

| VOLTAGE | P-035 - P-MC STANDARD | P-070/140 - P-FW HARD WIRE | P-MW STANDARD | HARD WIRE | STANDARD | HARD WIRE |
|---------|-----------------------|----------------------------|---------------|-----------|----------|-----------|
| 6 VDC | 21874-01 | 21875-01 | 21832-01 | 21833-01 | 22071-01 | 22065-01 |
| 12 VDC | 21874-02 | 21875-02 | 21832-02 | 21833-02 | 22071-02 | 22065-02 |
| 24 VDC | 21874-03 | 21875-03 | 21832-03 | 21833-03 | 22071-03 | 22065-03 |
| 24/60 | 21874-05 | 21875-05 | 21832-05 | 21833-05 | 22071-05 | 22065-05 |
| 115/60 | 21874-06 | 21875-06 | 21832-06 | 21833-06 | 22071-06 | 22065-06 |
| 230/60 | 21874-07 | 21875-07 | 21832-07 | 21833-07 | 22071-07 | 22065-07 |

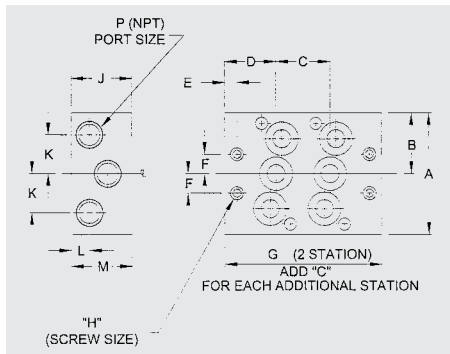

MANIFOLDS

| MODEL# | PART# | A | B | C | D | E | F | G | H | J | K | L | M | P |
|--------|-------|------|------|-------|-------|------|------|-------|-----|-------|------|------|-------|-----|
| P-035 | 21904 | 2.50 | 1.25 | .812 | .938 | .250 | .390 | 2.688 | #6 | 1.000 | .781 | .344 | .656 | 1/4 |
| P-070 | 21821 | 2.50 | 1.25 | 1.125 | 1.062 | .250 | .400 | 3.250 | #8 | 1.250 | .800 | .500 | .875 | 1/4 |
| P-140 | 21907 | 3.00 | 1.50 | 1.375 | 1.344 | .344 | .461 | 4.062 | #10 | 1.750 | .922 | .594 | 1.156 | 3/8 |

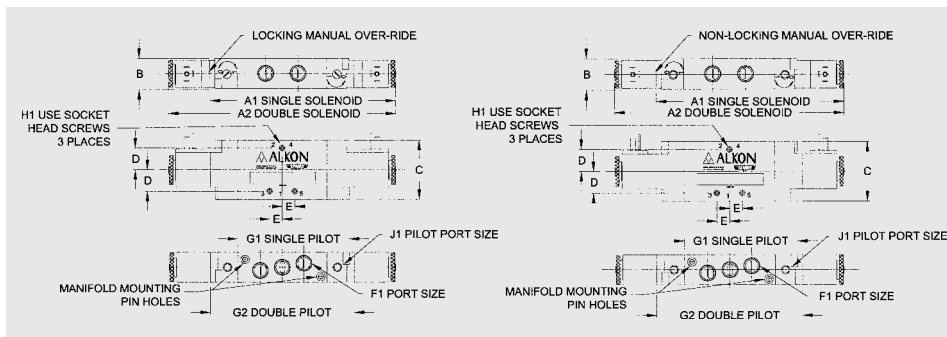

DIMENSIONS

| MODEL # | A1 | A2 | B | C | D | E | F1 | G1 | G2 | H1 | J1 |
|---------|------|------|------|------|------|------|---------|------|------|----|-------|
| P-035 | 4.58 | 6.88 | .750 | 1.50 | .594 | .325 | 1/8 NPT | 2.77 | 3.26 | #4 | 10-32 |
| P-070 | 5.16 | 7.80 | 1.00 | 2.00 | .750 | .359 | 1/4 NPT | 3.14 | 3.75 | #6 | 1/8 |
| P-140 | 6.01 | 8.77 | 1.25 | 2.50 | 1.00 | .435 | 3/8 NPT | 3.99 | 4.73 | #8 | 1/8 |



CONNECTORS:

In addition to the standard connectors and coils shown (see individual valve packages for part numbers), we also offer custom configurations such as different length cords, lighted wafers, light adapters, green or red LED's, and a variety of others. Contact your local Alkon distributor for more information.

VALVE ACCESSORIES

The dual exhaust and balanced design of the Alkon valve allows for the use of inexpensive exhaust metering valves. When screwed into the exhaust ports, they independently control the actuator speed in either or both directions.

Metering valves have aluminum bodies and steel adjusting screws.

Mufflers are used to silence the noise caused by exhausting air. Both standard mufflers and speed control mufflers are made of brass and sintered bronze.

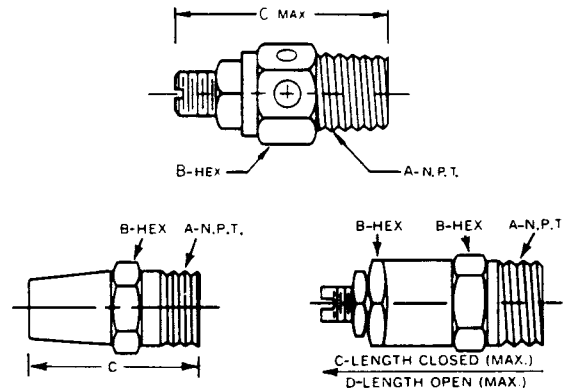

| MODEL NO. | DESCRIPTION | WEIGHT | DIMENSIONS | | | | Cv FACTOR |
|-----------|-------------------------------|---------|------------|-------|-------|-------|-----------|
| | | | A | B | C | D | |
| 6661 | 1/4 NPT Metering Valve | 1/2 oz. | 1/4 | .562 | 1.437 | - | 1.00 |
| 7985 | 3/8 NPT Metering Valve | 1 oz. | 3/8 | .687 | 1.812 | - | 1.55 |
| ER-50 | 1/2 NPT Metering Valve | 4 oz. | 1/2 | .875 | 2.0 | - | 1.75 |
| 40A01081 | #10-32 Exhaust Breather | 1/2 oz. | 10-32 | .312 | .40 | - | .20 |
| 9516-1 | 1/8 NPT Muffler | 1 oz. | 1/8 | .437 | 1.125 | - | .52 |
| 9516-2 | 1/4 NPT Muffler | 2 oz. | 1/4 | .562 | 1.375 | - | 1.10 |
| 9516-3 | 3/8 NPT Muffler | 3 oz. | 3/8 | .687 | 1.500 | - | 1.60 |
| 9516-4 | 1/2 NPT Muffler | 4 oz. | 1/2 | .875 | 1.875 | - | 3.20 |
| 9516-6 | 3/4 NPT Muffler | 5 oz. | 3/4 | 1.062 | 2.250 | - | 5.10 |
| 9516-8 | 1 NPT Muffler | 6 oz. | 1 | 1.312 | 2.875 | - | 10.0 |
| 9564-1 | 1/8 NPT Speed Control Muffler | 2 oz. | 1/8 | .562 | 1.375 | 2.000 | .59 |
| 9564-2 | 1/4 NPT Speed Control Muffler | 3 oz. | 1/4 | .625 | 1.562 | 2.187 | .77 |
| 9564-3 | 3/8 NPT Speed Control Muffler | 4 oz. | 3/8 | .687 | 1.875 | 2.813 | 1.31 |
| 9564-4 | 1/2 NPT Speed Control Muffler | 5 oz. | 1/2 | .875 | 2.250 | 3.312 | 2.60 |
| SCS-34 | 3/4 NPT Speed Control Muffler | 7 oz. | 3/4 | 1.062 | 2.375 | - | 4.80 |
| SCS-100 | 1 NPT Speed Control Muffler | 9 oz. | 1 | 1.312 | 2.500 | - | 8.50 |



OMNI SERIES VALVES

OMNI 150 / 250 / 375

Today's industrial fluid power operations demand faster, more reliable power and control air valve systems. Alkon's OMNI Series valves meet these needs . . .

- ▶ **A Broad Range of Applications** makes the OMNI Series best suited for the widest variety of applications – automation and machine tool control, packaging machinery, robotics clamping, fixtures, cylinder controls, and most other pneumatic devices.
- ▶ **Reaction Time** is fast and reliable, and will speed your production capability. For example, it takes less than 16 milliseconds to shift the valve spool.
- ▶ **Superior Performance** is guaranteed. OMNI Series valves are the fastest, lightest, most compact high-flowing valve packages in the industry. On the basis of performance, OMNI valves deliver more production per dollar spent.
- ▶ **Flexibility** is an outstanding feature of all OMNI Series valves. Air pilot or solenoid operated, base or manifold mounted, horizontal or vertical stacking or in-line mounting, OMNI Series valves can be configured to your specific production or maintenance requirements.
- ▶ **Stacking Feature** is another OMNI Series advantage. OMNI series valves can be assembled into a variety of stacking arrangements to reduce piping requirements and increase mounting options. These stacks offer high-flow performance in compact, space saving packages. Stacking models have been designed to reduce downtime and quick and easy valve add-ons, removals or other changes.

OMNI Series valves are specifically engineered to withstand harsh factory environments. OMNI valves are precision-machined, lightweight, compact and corrosion resistant. They're simple and easy to maintain, designed for reliable performance and minimum downtime.



DESIGN FEATURES:

- Patented Teflon loaded Viton "Thin Lip Seal"
- Minimum breakout friction
- Anodized extruded aluminum
- Compact size
- 2 and 3 position, 3 and 4-way
- Highest flow in industry
- Many standard body styles
- 50 standard primary operators
- Proven performer in both lubricated and dry systems
- Adaptable for vacuum and low pressures
- Operates on standard filtration
- Variety of mounting options
- Simple to maintain

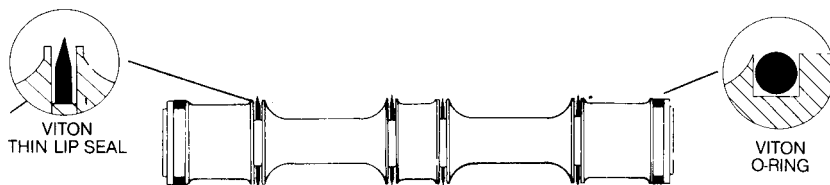

PATENTED "THIN LIP" SEAL & SPOOL FEATURES:

- Teflon loaded seals provide millions of trouble-free cycles
- Unique wiping action eliminates contaminant build-up in bore
- Reduces spool hang-up due to compressor or oil varnishing

HOW IT WORKS

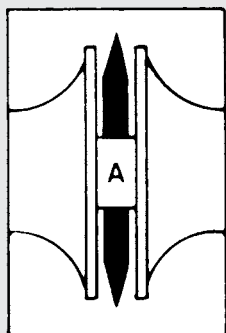

A. "Relaxed" no pressure on either side of seal.

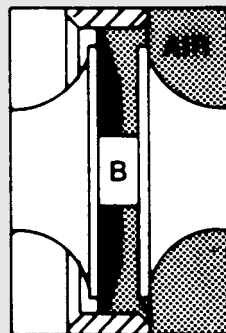

B. Pressure from right moves seal to left, expanding it against bore to sealed position.

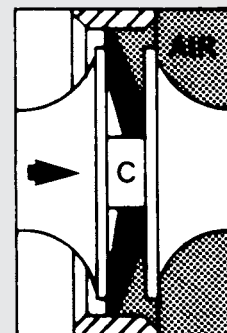









C. Force applied to left shifts spool... nominal sealing friction causes lip to flex like a diaphragm. Flexing action reduces breakdown friction. This spool can react quickly with very low force requirement.

ENGINEERING DATA FOR ALL OMNI VALVES

AVAILABILITY

| | 2-WAY | 3-WAY | 4-WAY | IN-LINE | STACKING | COMMON WIRE WAY | BASE MOUNTING | EXPLOS. PROOF |
|------------|------------|-------|-------|---------|----------|-----------------|---------------|---------------|
| 150 | Plug 3-Way | ✓ | ✓ | ✓ | ✓ | | | |
| 250 | Plug 3-Way | ✓ | ✓ | ✓ | ✓ | ✓ | ✓ | ✓ |
| 375 | Plug 3-Way | ✓ | ✓ | ✓ | ✓ | ✓ | ✓ | ✓ |

OPERATORS

| |  |  |  |  |  |  |  |  |
|------------|---|---|---|---|---|---|---|--|
| 150 | ✓ | ✓ | ✓ | | | | | |
| 250 | ✓ | ✓ | ✓ | | | | | |
| 375 | ✓ | ✓ | ✓ | ✓ | ✓ | ✓ | ✓ | ✓ |

OPERATOR REPLACEMENT

EXAMPLE: 375-37 120/60

- For air piloted valves, manual valves, and mechanically operated valves, furnish valve series and operator number only.
- For solenoid operators, specify voltage as well.

ENGINEERING DATA

| | OMNI 150 | OMNI 250 | OMNI 375 |
|---------------------------------------|----------------------|----------------------|----------------------|
| Media | Air and inert gasses | Air and inert gasses | Air and inert gasses |
| Maximum Operating Pressure | 150 PSI | 150 PSI | 150 PSI |
| Min. Pilot Pressure Solenoid/Solenoid | 20 PSI | 15 PSI | 15 PSI |
| Min. Pilot Pressure Solenoid/Spring | 45 PSI | 40 PSI | 45 PSI |
| Min. Pilot Pressure Air/Spring | 45 PSI | 40 PSI | 40 PSI |
| Min. Pilot Pressure Air/Air | 20 PSI | 15 PSI | 15 PSI |
| Vacuum To Below Min. Pilot | Available | Available | Available |
| Flow Rate @ 80 PSI (SCFM) | 28 | 56 | 108 |
| Max. Temperature | 185°F | 185°F | 185°F |
| For Other Temperatures | Consult Factory | Consult Factory | Consult Factory |

Pre-lubricated at factory to operate on lubricated or non-lubricated systems.

Cv FLOW

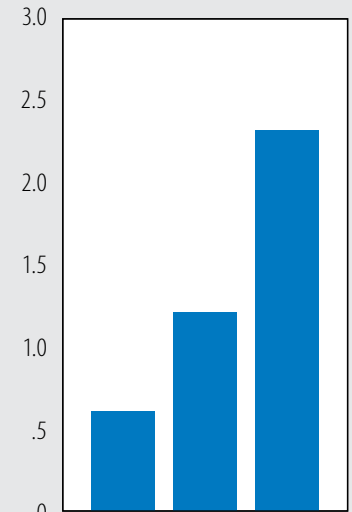

150 = .6CV = 28 SCFM
 250 = 1.2CV = 56 SCFM
 375 = 2.3CV = 108 SCFM

1 SCFM @ 80 PSIG = .073 dm³/s

LUBRICATION

All Alkon packed spool valves are pre-lubricated and will operate dry (with no additional lubrication), however a lubricated system will greatly extend the service life of any valve. Optional lubricants for special services are available.

The following oils are popular, easily obtainable fluids that are recommended for use with Alkon packed spool valves: Gulf Harmony 47, Mobil DTE Medium, Shell Tellus 29, Texaco Rondo B, Sohivis 47, Molubaloy, and Sunnis 921. Many other fluids are acceptable lubricants providing they do not contain detergents that will attack Buna N or Viton seals.

OMNI SERIES VALVES

ENGINEERING DATA FOR ALL OMNI VALVES *(Continued)*

SOLENOID SPECIFICATIONS

| STANDARD VOLTAGES | OMNI 150 | | OMNI 250 | | OMNI 375 | |
|-------------------|----------------|---------|----------------|----------------|----------------|----------------|
| | CURRENT (AMPS) | | CURRENT (AMPS) | | CURRENT (AMPS) | |
| | IN RUSH | HOLDING | IN RUSH | HOLDING | IN RUSH | HOLDING |
| 110/50Hz | .09 | .04 | .13 | .08 | .13 | .08 |
| 120/60Hz | .07 | .03 | .11 | .07 | .13 | .08 |
| 215/50Hz | | | .06 | .04 | .13 | .08 |
| 240/60Hz | | | .06 | .03 | .13 | .08 |
| 24/60Hz | | | .6 | .3 | .13 | .08 |
| 12VDC | .24 | .24 | .6 DIN=.87 | .6 DIN=.87 | .6 DIN=.87 | .6 DIN=.87 |
| 24/VDC | .12 | .12 | .29 DIN=.43 | .29 DIN=.43 | .29 DIN=.43 | .29 DIN=.43 |
| 120VDC | | | .05 | .05 | .13 | .08 |

- Other AC and DC Voltages Available Upon Request
- Explosion Proof Solenoids Available on Some Models
- All Solenoids Designed to Meet or Exceed U.L. & CSA Requirements

SOLENOID HOUSING CLASSIFICATION

Conduit & Grommet Housings with Molded Coils Meet:

- NEMA 1 General Purpose = Indoors
- NEMA 2 Dripproof = Indoors
- NEMA 3 Driptight = Indoors
- NEMA 4* Watertight & Dusttight = Indoors & Outdoors
- NEMA 6* Submersible, Watertight, Dusttight & Sleet-Ice Resistant = Indoors & Outdoors

**Specify "Potted Coil Option to meet NEMA 4 & 6"*

Explosion Proof Housings Meet:

- NEMA 7C, 7D & CSA
- Class I = Groups C & D = Explosion Proof
- NEMA 8C, 8D & CSA
- Class I = Groups C & D = Explosion Proof
- NEMA 9E, 9F, 9G & CSA
- Class II = Groups E, F & G = Explosion Proof

How the Sleeve & Plunger Solenoid Air Pilot Assembly Works

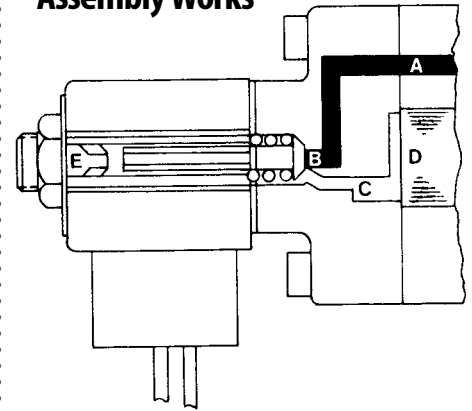

This diagram shows how this assembly works. Pilot air for the solenoid pilot is supplied from main line air through internal valve passage "A." With the solenoid in the de-energized position, the spring-loaded plunger seals against the air inlet "B." When the solenoid is energized, the plunger moves back and its top seat seals against the exhaust outlet "E." The top seat of the plunger is spring compensated against wear to assure complete, lifetime sealing. When the plunger moves off inlet port "B" the pilot air passes through outlet "C" to act on the end of the spool "D" causing the spool to shift. When the solenoid is de-energized, the plunger returns back to its starting position, the pilot air exhausts out of the spool chamber through inlet "C", past the plunger and out through outlet "E" to atmosphere.



REPLACEMENT PARTS

SPOOL REPLACEMENT

| OPERATOR # | OMNI 150 | | OMNI 250 | | | OMNI 375 | | |
|------------------|-----------------|-----------------|-----------------|----------------------------------|-------------------------------------|-----------------|----------------------------------|-------------------------------------|
| | 3-WAY 2 POS. | 4-WAY 2 POS. | 3-WAY 2 POS. | 4-WAY 2 POS. | 4-WAY 3 POS. | 3-WAY 2 POS. | 4-WAY 2 POS. | 4-WAY 3 POS. |
| 06 | N/A | N/A | | | | | | |
| 08 | N/A | N/A | N/A | N/A | N/A | 90A20095 | 90A20106 | N/A |
| 43 | N/A | N/A | | | | | | |
| 09 | N/A | N/A | N/A | N/A | N/A | 90A20078 | 90A20075 | N/A |
| 10 | N/A | N/A | N/A | N/A | N/A | 90A20078 | 90A20075 | N/A |
| 15, 19 | N/A | N/A | N/A | N/A | N/A | 90A20112 | 90A20113 | N/A |
| 15T, 19T | N/A | N/A | N/A | N/A | N/A | N/A | N/A | B90A20185 P90A20186 E90A20187 |
| 27, 30 31, 32 | N/A | N/A | N/A | N/A | N/A | 90A20201 | 90A20127 | N/A |
| ALL OTHERS | 90A20290 | 90A20289 | 90A20325 | 90A20225 ALUMINUM 90A20226 | B90A20230 P90A20231 E90A20232 | 90A20078 | 90A20075 ALUMINUM 90A20132 | B90A20175 E90A20176 P90A20177 |

COIL/SOLENOID REPLACEMENT

| OPERATOR # | OMNI 150 | | OMNI 250 | | OMNI 375 | |
|-------------------|--|----------|----------|----------|----------|----------|
| | COIL | SOL | COIL | SOL | COIL | SOL |
| 37 = 68 AC/DC | 26A01056 110/50 26A01057 24/VDC 26A01058 12VDC | 09A01064 | | | | |
| 33 = 67 AC/DC | 26A01056 110/50 26A01057 24VDC 26A01058 12VDC | 09A01065 | | | | |
| 60 AC DC | 26A01072 SPECIFY VOLTAGE | 09A01065 | | | | |
| 61 AC DC | 26A01072 SPECIFY VOLTAGE | 09A01064 | | | | |
| 33-37-38 64-65 | | | 26A01017 | 09A01001 | 26A01017 | 09A01001 |
| 42-66 | | | 26A01043 | 09A01039 | 26A01043 | 09A01039 |
| 60-61 62-63 | | | 26A01033 | 09A01023 | 26A01033 | 09A01023 |
| 67-68 82-86 | | | 26A01039 | 09A01038 | 26A01039 | 09A01038 |

OMNI SERIES VALVES

OMNI 150 SERIES VALVES

Flow Rating: .6 CV (2.04 dm³/s)

HOW TO ORDER OMNI 150 SERIES VALVES

| E | 150 | 02 | _____ | 011 | 37 | L | 1 | | | | | | | | | | | | | | | | |
|-------------------------------------|------------------------|--------------------------------------|--------------------------------------|---|--------------------------------------|--------------------------------------|---|----------|-------------|--------------------|--|--|---------------------|--|--|--------------------|--|--|---|----------------|-------------|---------------|-------------|
| Use When Ordering Metric Ports Only | Series (150) | Operator "B" (See Listing) | Operator Suffix (Optional) | Bodies | Operator "A" (See Listing) | Operator Suffix (Optional) | Voltages | | | | | | | | | | | | | | | | |
| | | | | <table border="1"> <thead> <tr> <th>First Digit Center Position</th> <th>Second Digit Port Size</th> <th>Third Digit Body Style/Type</th> </tr> </thead> <tbody> <tr> <td>0 = None</td> <td>1 = 1/8 NPT</td> <td>1 = In-line, 4-Way</td> </tr> <tr> <td></td> <td></td> <td>3 = Stacking, 4-Way</td> </tr> <tr> <td></td> <td></td> <td>7 = In-line, 3-Way</td> </tr> </tbody> </table> | First Digit Center Position | Second Digit Port Size | Third Digit Body Style/Type | 0 = None | 1 = 1/8 NPT | 1 = In-line, 4-Way | | | 3 = Stacking, 4-Way | | | 7 = In-line, 3-Way | | | <table border="1"> <tbody> <tr> <td>1 = 120/60 AC*</td> </tr> <tr> <td>2 = 12 VDC*</td> </tr> <tr> <td>3 = 24/60 AC*</td> </tr> <tr> <td>4 = 24 VDC*</td> </tr> </tbody> </table> | 1 = 120/60 AC* | 2 = 12 VDC* | 3 = 24/60 AC* | 4 = 24 VDC* |
| First Digit Center Position | Second Digit Port Size | Third Digit Body Style/Type | | | | | | | | | | | | | | | | | | | | | |
| 0 = None | 1 = 1/8 NPT | 1 = In-line, 4-Way | | | | | | | | | | | | | | | | | | | | | |
| | | 3 = Stacking, 4-Way | | | | | | | | | | | | | | | | | | | | | |
| | | 7 = In-line, 3-Way | | | | | | | | | | | | | | | | | | | | | |
| 1 = 120/60 AC* | | | | | | | | | | | | | | | | | | | | | | | |
| 2 = 12 VDC* | | | | | | | | | | | | | | | | | | | | | | | |
| 3 = 24/60 AC* | | | | | | | | | | | | | | | | | | | | | | | |
| 4 = 24 VDC* | | | | | | | | | | | | | | | | | | | | | | | |
| | | | | <p>NOTE: In-line 3-Way bodies are field convertible to normally open or normally closed.</p> | | | *Denotes standard voltages – others available on request. | | | | | | | | | | | | | | | | |

| OPERATOR SUFFIX - OPTIONAL | | |
|----------------------------|-------------------|--------------|
| Letter Code | Description | Availability |
| L | Lighted Connector | 68 |
| R | Red, HD Spring | 02 |
| Y | .8 Watt Sol., DIN | 68 (DC Only) |

Additional operators available, consult factory

| OPERATOR: | |
|-----------|---|
| 02 | Spring Return |
| 03 | Air Pilot |
| 61 | Solenoid with lead wires and manual override |
| 68 | Solenoid with DIN connector and manual override |

ORDERING PROCEDURE FOR OMNI 150 SERIES:

- Series:** Identifies valve series
- Operator:** B - secondary - returns spool
Operator suffix if applicable
- Body:** The body style selects type of mounting and port sizes
- Operator:** A - primary operator
Operator suffix if applicable
- Volts:** Specify dash number

VALVE STACK ORDERING PROCEDURE:

- All 150 Series valve stacks are assembled with tie rods at the factory at no additional charge.
- To order, first list the model and quantity of each valve required. Second, specify the size of end plate assembly required (1/4 ports).
- Consult the factory for other options.



OMNI 150 SERIES VALVES

| OPERATOR | PIPE SIZE | MODEL # | SCHEMATIC |
|-----------------------------|-----------|---------------|-----------|
| Air Pilot | M5 | 150-02-031-03 | |
| Spring Return | 1/8 | 150-02-011-03 | |
| Double Air | M5 | 150-03-031-03 | |
| Pilot | 1/8 | 150-03-011-03 | |
| OPERATOR | PIPE SIZE | MODEL # | SCHEMATIC |
| Double Solenoid with Manual | M5 | 150-68-031-68 | |
| Override | 1/8 | 150-68-011-68 | |



4-Way/Air Pilot



4-Way/Solenoid

OPERATORS

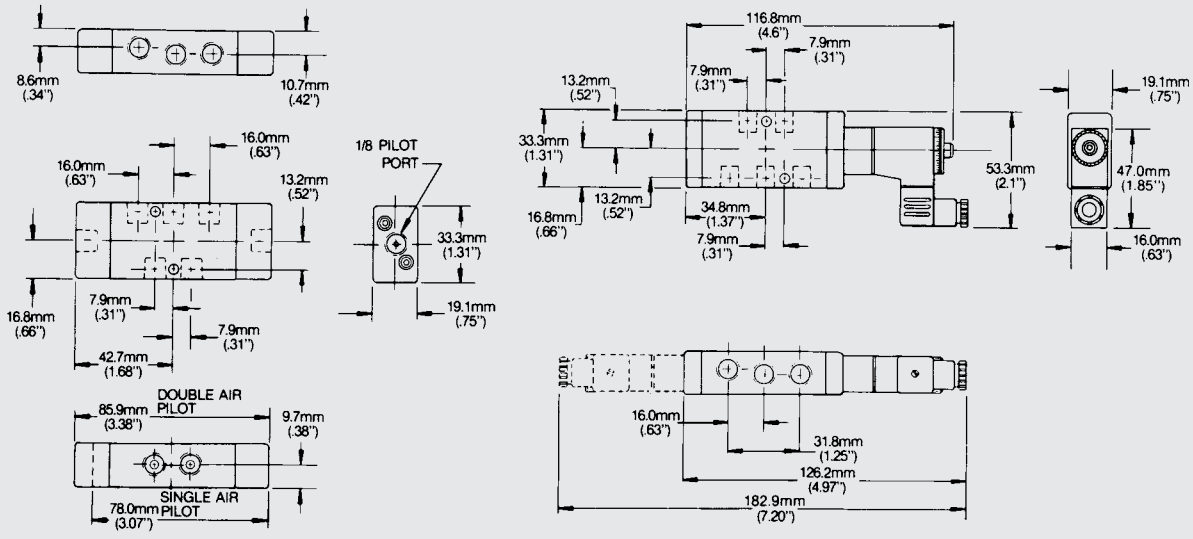
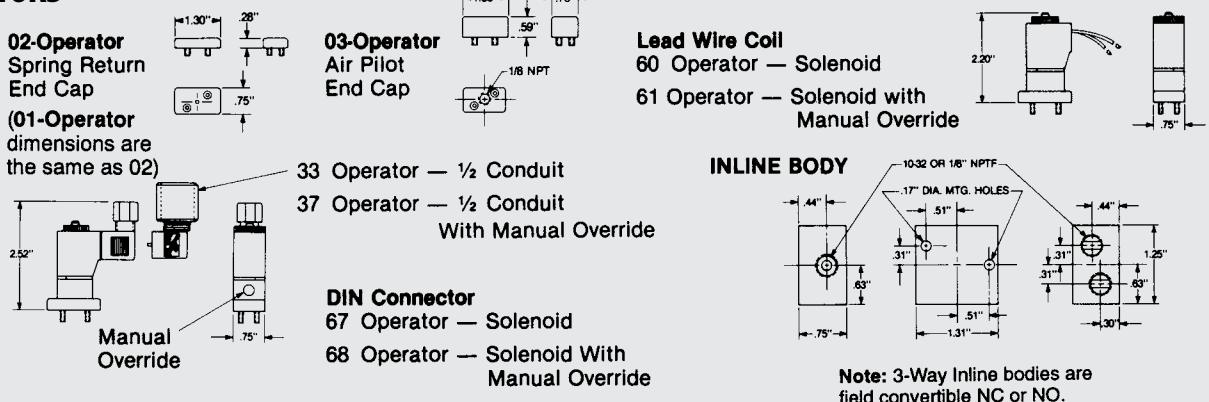

OMNI SERIES VALVES

OMNI 150 SERIES VALVES

NEW "FLIP-OUT" DESIGN

The Alkon "Flip-Out" design is a special OMNI valve feature which makes valve changes, add-ons or removals quick and easy. Notched valve bodies and end plates permit "Flip-Out" valve replacement or stack rearrangement in seconds. Simply loosen top tie-rod, remove and lift out valve.

| END PLATE ASSEMBLY FOR STACKING 4-WAY | | |
|---------------------------------------|-----|------------|
| 150-H14 | 1/4 | Horizontal |

Note: End Plate Assembly furnished with 2 End Plates, 3 Tie Rods, All Nuts and O-Rings required.

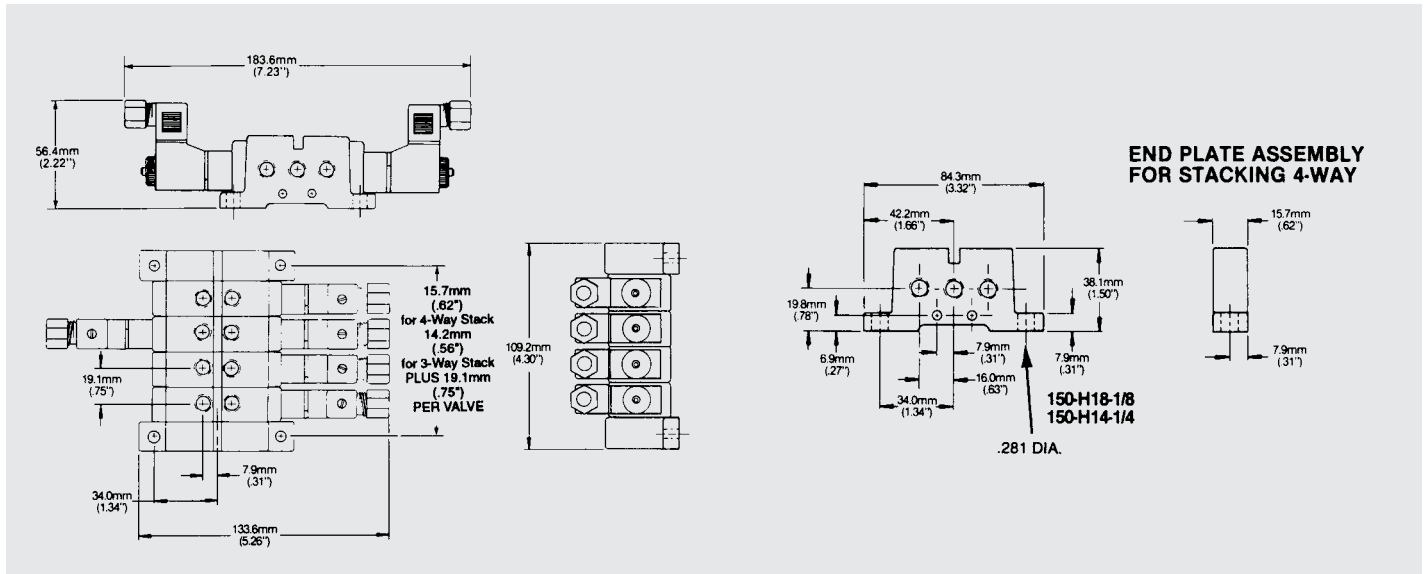

OMNI 250 SERIES VALVES

Flow Rating: 1.2 CV (4.09 dm³/s)

HOW TO ORDER OMNI 250 SERIES VALVES

| E | 250 | 02 | _____ | 011 | | | 37 | E | 1 |
|-------------------------------------|------------------------|--------------------------------------|--------------------------------------|------------------------------------|-------------------------------|--|--------------------------------------|--------------------------------------|-----------------|
| Use When Ordering Metric Ports Only | Series (250) | Operator "B" (See Listing) | Operator Suffix (Optional) | Bodies | | | Operator "A" (See Listing) | Operator Suffix (Optional) | Voltages |
| | | | | First Digit Center Position | Second Digit Port Size | Third Digit Body Style/Type | | | |
| | | | | 0 = None | 0 = 1/4 NPT | 0 = Body Blank, 4-Way | | | |
| | | | | B = Blocked | 1 = 1/8 NPT | 1 = In-line, 4-Way | | | |
| | | | | E = Exhausted | | 2 = Stacking, 4-Way Ind'l Exhaust | | | |
| | | | | | | 3 = Stacking, 4-Way | | | |
| | | | | | | 4 = Base Mounted | | | |
| | | | | | | 7 = In-line, 3-Way | | | |
| | | | | | | 9 = Stacking, 4-Way Common Wireway Mount | | | |
| | | | | | | | 1 = 120/60 AC* | | |
| | | | | | | | 2 = 12 VDC* | | |
| | | | | | | | 3 = 24/60 AC* | | |
| | | | | | | | 4 = 240/60 AC* | | |
| | | | | | | | 5 = 24 VDC* | | |

| OPERATOR SUFFIX - OPTIONAL | | |
|----------------------------|--------------------------------------|--------------|
| Letter Code | Description | Availability |
| H | Class H Coil, Viton Sleeve & Plunger | 37 |
| L | Lighted Connector | 67, 68, 82 |
| R | Red, HD Spring | 02 |

| OPERATOR NUMBER: | |
|------------------|---|
| 02 | Spring Return |
| 03 | Air Pilot |
| 37 | Solenoid with 1/2" conduit connection & manual override |
| 42 | Solenoid - explosion proof |
| 68 | Solenoid with DIN connector & manual override |
| 82 | Solenoid with DIN connector, locking manual override |

Additional operators available, consult factory.

*Denotes standard voltages – others available on request.

ORDERING PROCEDURE FOR OMNI 250 SERIES:

- Series:** Identifies valve series
- Operator:** B - secondary - returns spool
Operator suffix if applicable
- Body:** The body style selects type of mounting & port sizes
- Operator:** A - primary operator
Operator suffix if applicable
- Volts:** Specify dash number
- For stacking valves refer to page 37 & 38

Note: Air pilot or solenoid operators may be used with either 2 position or 3 position body styles



OMNI SERIES VALVES

OMNI 250 SERIES VALVES

AIR PILOT OPERATED

The OMNI Series 3-Way and 4-Way valves can be air pilot operated with three types of assemblies:

1. **DOUBLE AIR PILOT (NO VALVE SPOOL SPRING).** The valve spool is shifted by a momentary air pilot signal to either of the "A" or "B" Pilots.
2. **SINGLE AIR PILOT, SPRING RETURN.** The valve spool is maintained in the normal rest position in the "B" end. A maintained air pressure signal at the "A" end greater than the spring force will shift the valve spool.
3. **DOUBLE AIR PILOT, SPRING OFFSET.** The valve spool is maintained in the normal rest position in the "B" end. A maintained air pressure signal at the "A" end greater than the spring force will shift the valve spool, providing no air pressure signal is on the "B" end. By controlling the pressure differential between "A" and "B" a variety of applications are available.

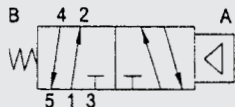
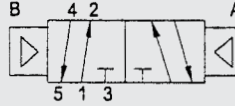
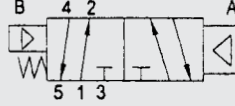
| DESCRIPTION | BASIC VALVE MODEL NUMBERS | | SCHEMATICS |
|--------------------------------|---------------------------|---------------|---|
| | PIPE SIZE | NUMBER | |
| Air Pilot Spring Return | 1/8 NPTF | 250-02-011-03 |  |
| | 1/4 NPTF | 250-02-001-03 | |
| Double Air Pilot | 1/8 NPTF | 250-03-011-03 |  |
| | 1/4 NPTF | 250-03-001-03 | |
| Double Air Pilot Spring Offset | 1/8 NPTF | 250-04-011-03 |  |
| | 1/4 NPTF | 250-04-001-03 | |



3-Way/Air Pilot



4-Way/Air Pilot

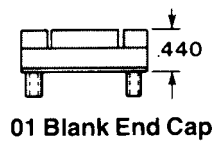

01 Blank End Cap

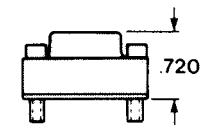

03 Air Pilot

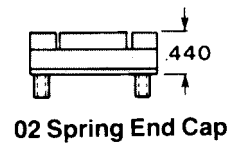

02 Spring End Cap

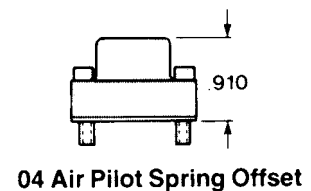

04 Air Pilot Spring Offset

Double Air Pilot

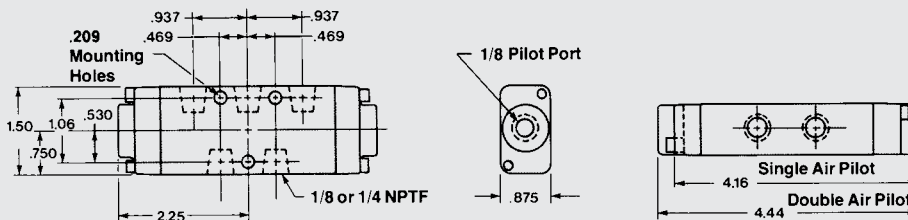

Note: For 3-Way body see page 35

03 Air Pilot

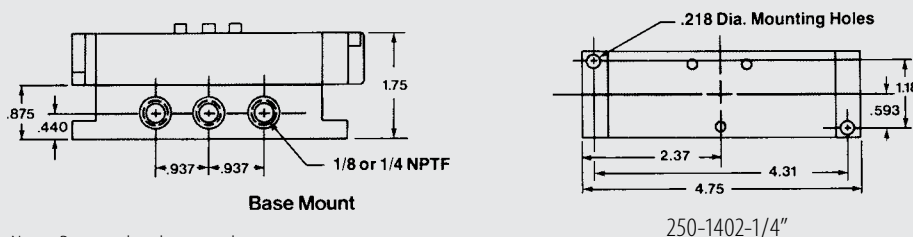

Note: Bases ordered separately

OMNI 250 SERIES VALVES

SOLENOID AIR PILOT OPERATED

The OMNI 250 3-Way and 4-Way Solenoid Air Pilot Operated Valves Offer these Special Electrical Features:

- Solenoid assembly so reliable it's guaranteed
- A variety of standard AC or DC voltage options
- Plug-in electrical connectors
- Explosion proof operators
- All coils molded epoxy
- Built to meet or exceed UL standards
- Intrinsically safe operators available
- Class H, hi-temp solenoids available

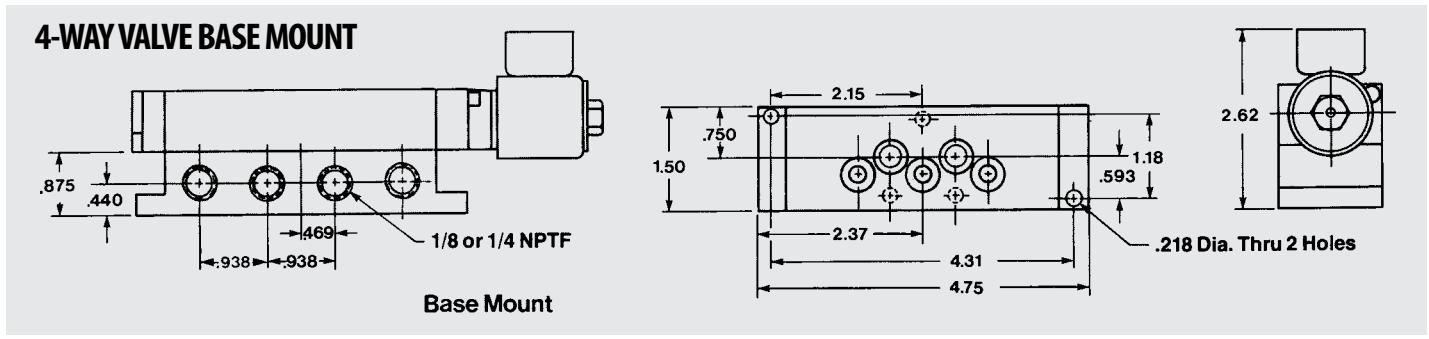
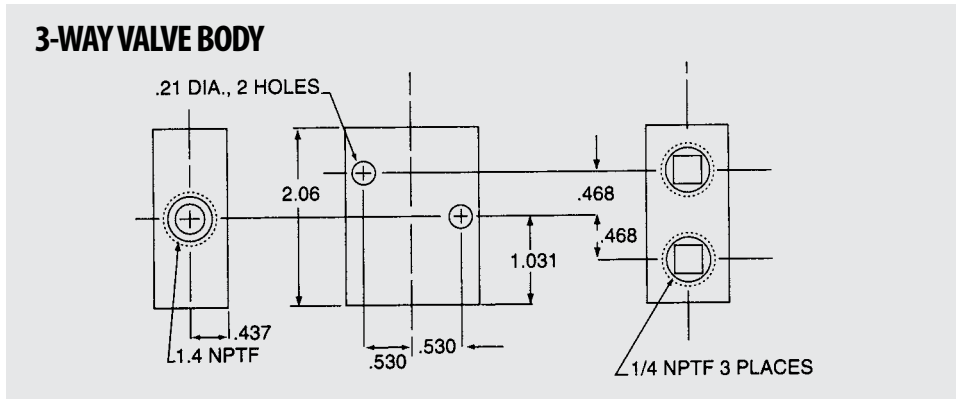
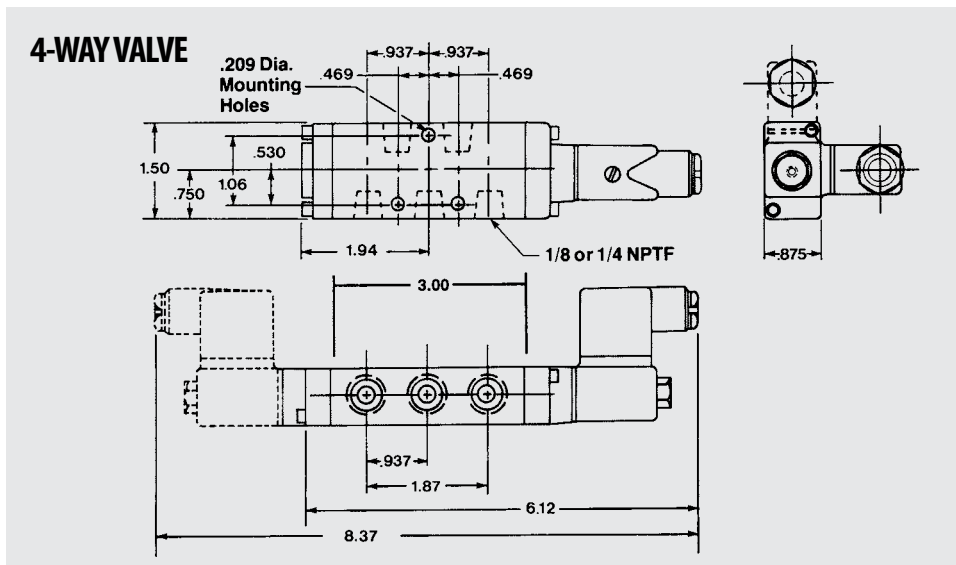

Single Solenoid Spring Return with Manual Override, Explosion Proof

| BASIC VALVE MODEL NUMBERS | |
|---------------------------|---------------|
| PIPE SIZE | NUMBER |
| 1/8 NPTF | 250-02-011-42 |
| 1/4 NPTF | 250-02-001-42 |

SCHEMATICS

Schematic diagram showing a 4/2-way valve with a spring return. Ports are labeled B, 4, 2, A, 5, 1, 3.

Double Solenoid Momentary Contact and Manual Override

| BASIC VALVE MODEL NUMBERS | |
|---------------------------|---------------|
| PIPE SIZE | NUMBER |
| 1/8 NPTF | 250-37-011-37 |
| 1/4 NPTF | 250-37-001-37 |

SCHEMATICS

Schematic diagram showing a 4/2-way valve with two solenoids and a spring return. Ports are labeled B, 4, 2, A, 5, 1, 3.

OMNI SERIES VALVES

OMNI 250 SERIES VALVES

SOLENOID AIR PILOT OPERATED

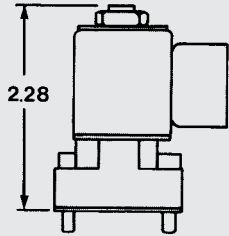

Conduit Connection

37 Solenoid with Non-Locking Manual Override

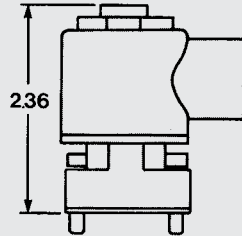

Explosion Proof

42 Explosion Proof Solenoid with Manual Override

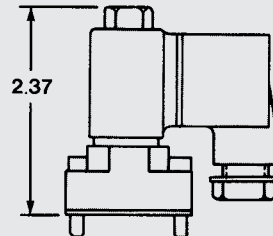

DIN Connector

68 Solenoid with Manual Override
82 Solenoid with Locking Manual Override

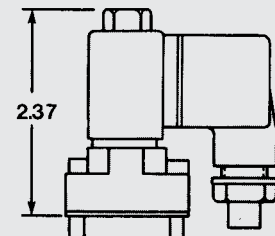

Common Wireway

68C Solenoid with Manual Override
82c Solenoid with Locking Manual Override

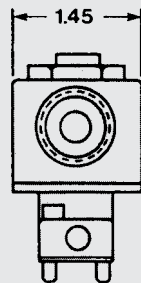

42 Non-Locking Override Push Type
Shown With Explosion Proof



Locking Override Push and Turn
Shown with DIN Connector

Note: 55 in.-lbs. nut torque



OMNI 250 SERIES VALVES

STACKING & COMMON WIREWAY ARRANGEMENTS

The OMNI 250 Series valves can be assembled into a variety of stacking arrangements which greatly reduce piping requirements and increase mounting options. These stacks offer high flow performance in compact, space saving packages which include:

- 4-Way, 5 ported stacks with common input and dual common exhaust or individual exhaust
- Available tapped 1/8 or 1/4 NPTF
- Horizontal or vertical mounting
- Available with common electrical wireway
- 2 and 3 position
- Dual pressure available via blocking disc #32A01010
- Common External Pilot available



Wireway Arrangement

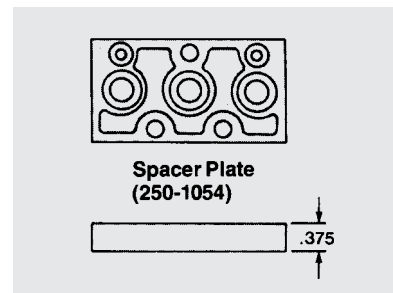

Ordering Information:

All 250 Series valve stacks are assembled with tie rods at the factory at no additional charge. To order, first list the quantity and model of each type of valve required, (see page 33). Second, determine the number of 3/8" wide spacers required between each valve. When 03, 04, 60Y, 61Y, 62Y, 63Y, 67, 68 and 82 operators are used, spacers are not required. When 09, 13, 15, 15Tm, 33m, 37, 38 and 50, 51, 52, 53, 60, 61, 64 and 65 operators are used, allow one spacer between each valve, but not between a valve and end plate. For 42 operators, use two spacers between each valve but not between a valve and end plate. For common electrical wireway, spacers are not required. Third, specify the type of end plate assembly required (horizontal or vertical mounting and 1/8 or 1/4 NPTF ports). Fourth, for common wireway stack, specify model enclosure. (See examples shown on right column of this page.)

Example:

- (2) 250 Series stack each consisting of:
 - (4) 250-02-013-37 120/60 valve
 - (3) 250-1054 spacer plate
 - (1) 250-1333 horizontal end plate assembly 1/8 NPTF

Example:

- (2) 250 Series stack each consisting of:
 - (4) 250-02-019-68C 120/60 valve
 - (1) 250-1334 spacer plate assembly
 - (1) 25-1131 Single solenoid enclosure

| ORDER NUMBERS FOR COMMON WIREWAY NEMA 4 ENCLOSURE | |
|---|-----------------|
| DESCRIPTION | MODEL |
| 2 thru 4 single solenoid enclosure* | 25-1131 |
| 2 thru 4 double solenoid enclosure* | 25-1132 |
| 5 thru 6 single solenoid enclosure | 25-1133 |
| 5 thru 6 double solenoid enclosure | 25-1134 |
| 7 thru 10 single solenoid enclosure | 25-1135 |
| 7 thru 10 double solenoid enclosure | 25-1136 |
| 11 + valves | Consult factory |

* When ordering a 2 valve stack, one extra spacer must be ordered - #45A01058. If any one valve in stack is double solenoid, you must order double solenoid enclosure.

| ORDER NUMBERS FOR COMMON WIREWAY & STANDARD STACK END PLATE ASSEMBLIES | |
|--|----------|
| DESCRIPTION | MODEL |
| Vertical mount assembly (1/4 NPTF ports) | 250-1334 |
| Horizontal mount assembly (1/4 NPTF ports) | 250-1333 |
| Spacer Plate | 250-1054 |



OMNI SERIES VALVES

OMNI 250 SERIES VALVES

STACKING ARRANGEMENTS

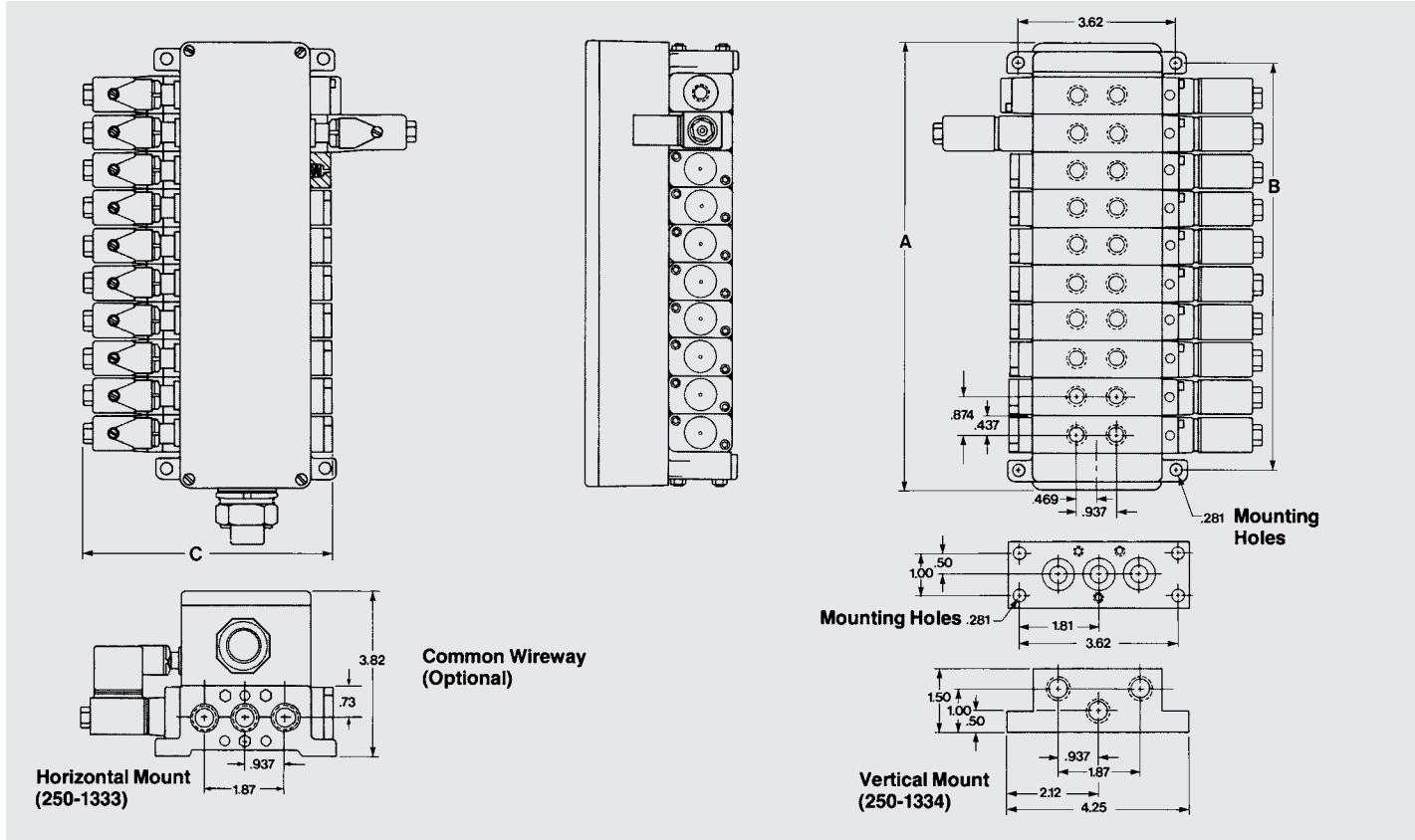

| NO. VALVES | A | B | VALVE STYLE | C |
|------------|------|------|--------------------------------------|------|
| 2 or 3 | 5.00 | 3.38 | 2 Pos. Single Solenoid Spring Return | 5.86 |
| 4 | 5.00 | 4.25 | | |
| 5 | 7.00 | 5.13 | 2 Pos. Single Solenoid Air Return | 6.07 |
| 6 | 7.00 | 6.00 | | |
| 7 | 9.80 | 6.88 | 2 Pos. Double Solenoid | 7.70 |
| 8 | 9.80 | 7.75 | | |
| 9 | 9.80 | 8.63 | | |
| 10 | 9.80 | 9.50 | | |

Note: Horizontal end plates may be attached with either the mounting feet on the port side or the side opposite. Unless otherwise specified, all common wireway stacks have the mounting feet on the port side and all other stacks have the feet on the side opposite the ports. When ordering, if more than one model number valve is to be stacked, specify valve position by numbering valves from left to right while facing the "B end" operators. If a vertical mounting plate is used, number valves starting from vertical plate.

Example:

- 250 Stack Consisting of:
- (2) 250-02-003-03 air pilot
- (1) 250-02-003-68 DIN connector
- (1) 250-02-013-60Y grommet
- (1) 250-02-003-03 air pilot
- (1) 250-01-003-15 lever
- (1) 250-02-013-37 conduit
- (1) 250-02-003-42 ex. proof
- (4) 250-1054 spacer plate
- (1) 250-1333 end plate assembly

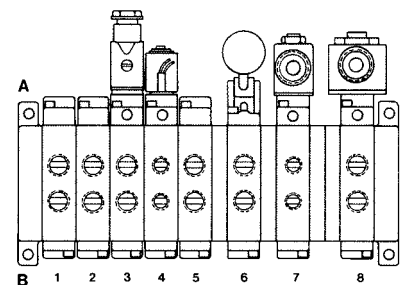

OMNI 250 SERIES VALVES

REPLACEMENT PARTS

Spool Replacement



3 Position "B"
90A20230

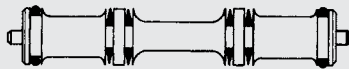

3 Position "P"
90A20231



3 Position "E"
90A20232



3 Position "B" Lever
90A20233



3 Position "P" Lever
90A20234



3 Position "E" Lever
90A20235



2 Position Palm Button
90A20227

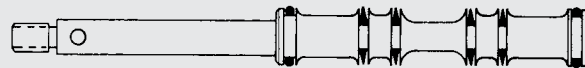

2 Position Panel MTD. Palm Button
90A20228



2 Position Lever
90A20229



2 Position
90A20225 - Aluminum Spool - Mechanical Operators
90A20226 - Plastic Spool - Solenoid and Air Operators

COIL REPLACEMENT

| DESCRIPTION | MODEL |
|---|----------|
| Coil with conduit housing, 7 watt, 33, 37, 38, 64, 65 operators | 26A01017 |
| Coil or Grommet Connection, 7 watt, 59, 60, 61 operators | 26A01033 |
| Coil with DIN connector, 8.5 watt, 67, 68, 82, 67C, 82C operators | 26A01039 |
| Coil with explosion proof housing, 7 watt, 42, 66 operators | 26A01043 |

When ordering coil, give part number and voltage.
Standard voltages are: 120/60, 240/60, 6VDC, 24VDC. For other voltages consult factory.

Torque Settings for Coil Hold Down Nuts are:

- 20-25 in-lbs. for Canned type operators
- 20-25 in-lbs. for DIN operators
- 55 in-lbs. for operators 42

OMNI SERIES VALVES

OMNI 375 SERIES VALVES

Flow Rating: 2.3 CV (7.88 dm³/s)

HOW TO ORDER OMNI 375 SERIES VALVES

| E | 375 | 02 | _____ | 011 | 67 | L | 1 |
|-------------------------------------|------------------------|--------------------------------------|--------------------------------------|---|--------------------------------------|--|-----------------|
| Use When Ordering Metric Ports Only | Series (375) | Operator "B" (See Listing) | Operator Suffix (Optional) | Bodies | Operator "A" (See Listing) | Operator Suffix (Optional) | Voltages |
| | | | | First Digit Center Position | Second Digit Port Size | Third Digit Body Style/Type | 1 = 120/60 AC* |
| | | | | 0 = None | 0 = 1/4 NPT | 1 = In-line, 4-Way | 2 = 12 VDC* |
| | | | | B = Blocked | 8 = 3/8 NPT | 2 = Stacking, 4-Way Ind'l Exhaust | 3 = 24/60 AC* |
| | | | | E = Exhausted | | 3 = Stacking, 4-Way | 4 = 240/60 AC* |
| | | | | P = Pressurized | | 4 = Base Mounted | 5 = 24 VDC* |
| | | | | Additional threads available – consult factory. | | 7 = In-line, 3-Way | |
| | | | | | | 9 = Stacking, 4-Way Common Wireway Mount | |

| OPERATOR SUFFIX - OPTIONAL | | |
|----------------------------|--|--------------------|
| Letter Code | Description | Availability |
| F | Filtered & Potted Solenoid for NEMA 4 Solenoid | 33, 37, 38, 64, 65 |
| H | Class H Coil, Viton Sleeve & Plunger | 33, 37, 38, 64, 65 |
| L | Lighted Connector | 67, 68, 82, 86 |
| R | Red, HD Spring | 02, 04 |
| R | Red Palm Button | 9 thru 12, 14, 43 |

*Denotes standard voltages – others available on request.



ORDERING PROCEDURE FOR OMNI 375 SERIES:

- Code:** E - Use when ordering metric ports only
- Series:** Identifies valve series
- Operator:** B - secondary - returns spool
Operator suffix if applicable
- Body:** The OMNI 375 is a 2 or 3 position valve
The body style selects type of mounting & port sizes
(see page 49 for 3 position valves)
- Operator:** A - primary operator
Operator suffix if applicable
- Specify voltages or any other special conditions
- For stacking valves, refer to pages 50 & 51
- For manifold valves, refer to pages 52 & 53

OMNI 375 SERIES VALVES

OPERATOR NUMBER:

| | |
|----|--|
| 01 | Blank end cap |
| 02 | Spring Return |
| 03 | Air Pilot |
| 04 | Air Pilot - Spring offset |
| 05 | 7/8" diameter knob push to operate |
| 06 | 7/8" diameter knob detented, (must be used with 01 operator) |
| 07 | 7/8" diameter knob, panel mounted, push to operate |
| 08 | 7/8" diameter knob, panel mounted, detented, (must be used with 01 or 03 operator) |
| 09 | Palm button, push to operate |
| 10 | Panel Mount Palm button spring return |
| 12 | Palm button, panel mounted, push to operate |
| 13 | Lever, parallel, push to operate |
| 14 | Palm button, detented, push-pull to operate (must be used with 01 operator) |
| 15 | Lever, parallel, detented, push-pull to operate (must be used with 01 operator) |
| 17 | Lever, perpendicular, push to operate (must be used with 02 operator) |
| 19 | Lever, perpendicular, detented, push-pull to operate (must be used with 01 operator) |
| 27 | Plunger operator |
| 30 | Roller lever, actuation left (reference supply port-right) (use with 02 operator) |
| 31 | Roller lever, actuation right (reference supply port-right) (use with 02 operator) |
| 32 | Roller lever, 2-Way actuation (use with 02 operator) |
| 33 | Solenoid with 1/2" conduit ports |
| 34 | Foot pedal (must use with 02R operator) |
| 37 | Solenoid with 1/2" conduit connection and manual override |
| 38 | Solenoid with 1/2" conduit connection and locking manual override |
| 39 | Foot treadle, detented (must be used with 01 operator) |
| 42 | Solenoid - explosion proof, conduit connection, manual override |
| 43 | Panel mount palm button, push-pull to operate detented (must be used with 01 operator) |
| 59 | Solenoid with lead wires and locking manual override |
| 60 | Solenoid with lead wires |
| 61 | Solenoid with lead wires, manual override |
| 65 | Solenoid with 1/2" conduit connection, manual override, external pilot supply |
| 67 | Solenoid with DIN connector |
| 68 | Solenoid with DIN connector and manual override |
| 70 | Air pilot with shuttle - auxiliary port plugged |
| 81 | Air pilot with spool position indicator, manual override |
| 82 | Solenoid with DIN connector, locking manual override |
| 83 | Air pilot, manual actuator |
| 86 | Solenoid with DIN connector, manual override, external pilot supply |



OMNI SERIES VALVES

OMNI 375 SERIES VALVES

3-WAY & 4-WAY SOLENOID AIR PILOT OPERATED

The OMNI 375 3-Way and 4-Way solenoid air pilot operated valves offer these special electronic features:

- Solenoid assembly so reliable it's guaranteed.
- Explosion proof operators.
- A variety of standard AC or DC voltage options.
- All coils molded epoxy – standard.
- Dual rated solenoids for 50/60 cycles.
- Build to meet or exceed UL standards.
- Plug in electrical connectors.
- Class H, hi-temp solenoid available.



3-Way

33 Operator

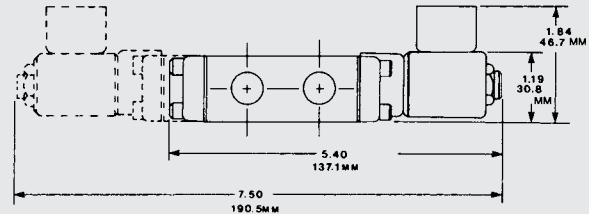
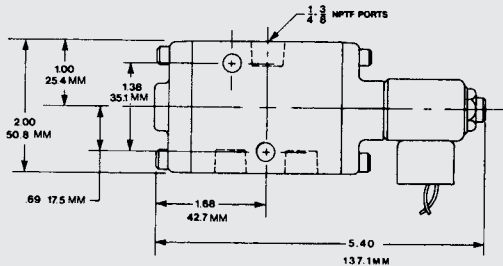

4-Way

33 Operator

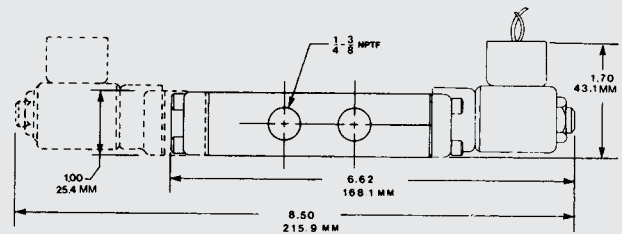
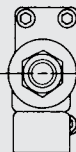
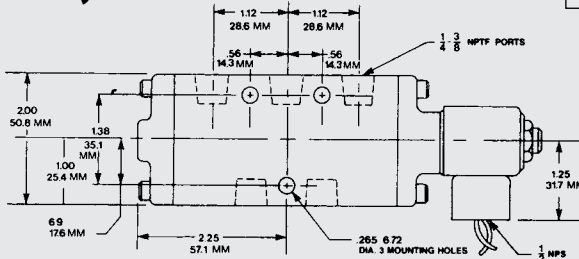

Base Mount

33 Operator

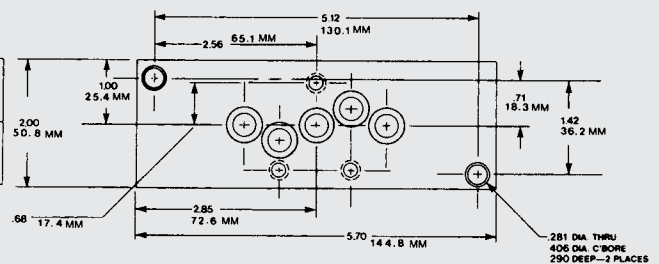
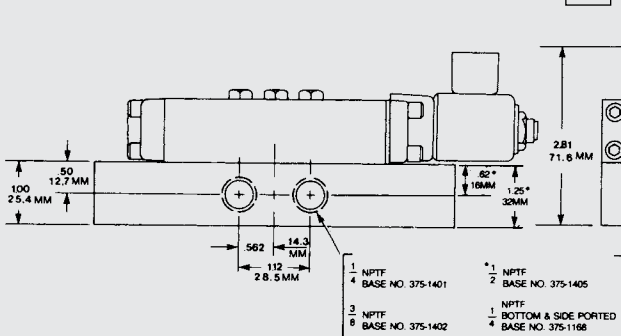

OMNI 375 SERIES VALVES

BASIC VALVE MODEL NUMBERS

| DESCRIPTION | 3-WAY | | | 4-WAY | | |
|--|-----------|---------------|------------|-----------|---------------|------------|
| | PIPE SIZE | NUMBER | SCHEMATICS | PIPE SIZE | NUMBER | SCHEMATICS |
| Double Solenoid Momentary Contact with Manual Override | 1/4 NPTF | 375-37-007-37 | | 1/4 NPTF | 375-37-001-37 | |
| | 3/8 NPTF | 375-37-087-37 | | 3/8 NPTF | 375-37-081-37 | |
| Single Solenoid Spring Return with Manual Override | 1/4 NPTF | 375-02-007-37 | | 1/4 NPTF | 375-02-001-37 | |
| | 3/8 NPTF | 375-02-087-37 | | 3/8 NPTF | 375-02-081-37 | |

Optional Solenoid Operators

This series of 4-Way valves is available with base mounting which permits the removal or changing of a valve without disturbing the piping. The 374 Series valve is machined from extruded aluminum and available with 5 threaded ports in 1/4 or 3/8 NPTF. The valve body (004) has 5 unthreaded ports on the wide part of the valve which mate with the 5 ports on the top of the base. The body is supplied with 5 Viton O-rings and is assembled to the base.

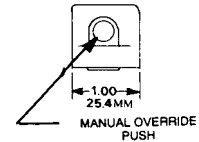

- 33 Solenoid Air Pilot Conduit Connection
- 37 Solenoid Air Pilot with Manual Override And Conduit Connection
- 38 Solenoid Air Pilot with Locking Manual Override

- 59 Solenoid Air Pilot with Lead Wires And Locking Manual Override
- 60 Solenoid Air Pilot with Lead Wires
- 61 Solenoid Air Pilot with Lead Wires and Manual Override

- 67 DIN Connector
- 68 DIN Connector with Manual Override
- 82 DIN Connector with Locking Manual Override
- 86 DIN Connector with Manual Override External Pilot Supply

- 67C DIN Connector
- 68C DIN Connector with Manual Override
- 82C DIN Connector with Locking Manual Override
- 86C DIN Connector with Manual Override External Pilot Supply

42 Explosion Proof Solenoid

| DESCRIPTION | PIPE SIZE | NUMBER |
|--|-----------|---------------|
| Single solenoid, spring return valve, base mounted, valve only | | 375-02-004-37 |
| Side Ported Base | 1/4 NPTF | 375-1401 |
| | 3/8 NPTF | 375-1402 |
| | 1/2 NPTF | 375-1405 |
| Side & Bottom Ported Base | 1/4 NPTF | 375-1168 |

Note: Valves and bases must be ordered separately

Normally Closed/Normally Open Valves

Note: Unless otherwise specified, all 375 Series 3-Way solenoid valves are supplied as Normally Closed and the #3 port is the supply port. If a Normally Open valve is required, it must be specified and the #1 port must be piped as the supply port. EXAMPLE: N0375-02-007-33 120/60

All solenoid operators available in the following voltages: 120/60, 240/60, 6VDC, 12VDC, 24VDC. For other voltages, Class H or low watt coils, consult factory.

OMNI SERIES VALVES

OMNI 375 SERIES VALVES

3-WAY & 4-WAY AIR PILOT OPERATED

The OMNI 375 Series 3-Way and 4-Way Valves can be Air Pilot Operated with three types of assemblies:

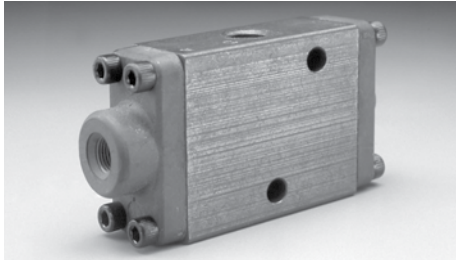

Single Air Pilot, Spring Return

The valve spool is maintained in the normal rest position by the spring in the "B" end. A maintained air pressure signal at the "A" end greater than the spring force will shift the valve spool.

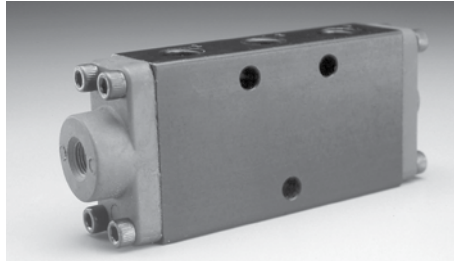

Double Air Pilot (No Valve Spool Spring)

The valve spool is shifted by a momentary air pilot signal to either of the "A" or "B" Pilots.

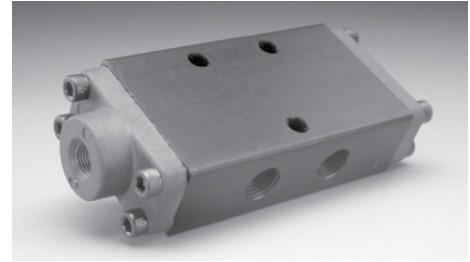

Double Air Pilot, Spring Offset

The valve spool is maintained in the normal rest position by a spring in the "B" end. A maintained air pressure signal at the "A" end greater than the spring force will shift the valve spool, providing no air pressure signal is on the "B" end. By controlling the pressure differential between "A" and "B," a variety of applications are possible.

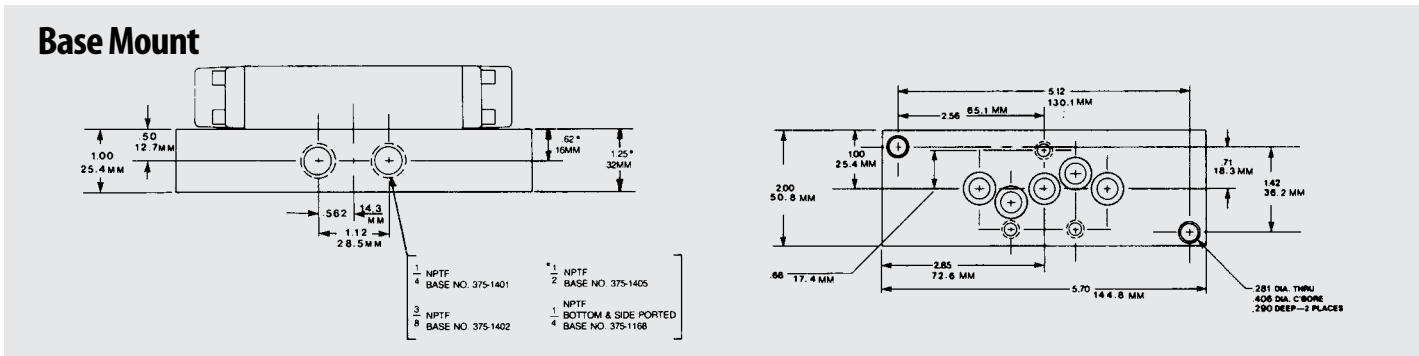
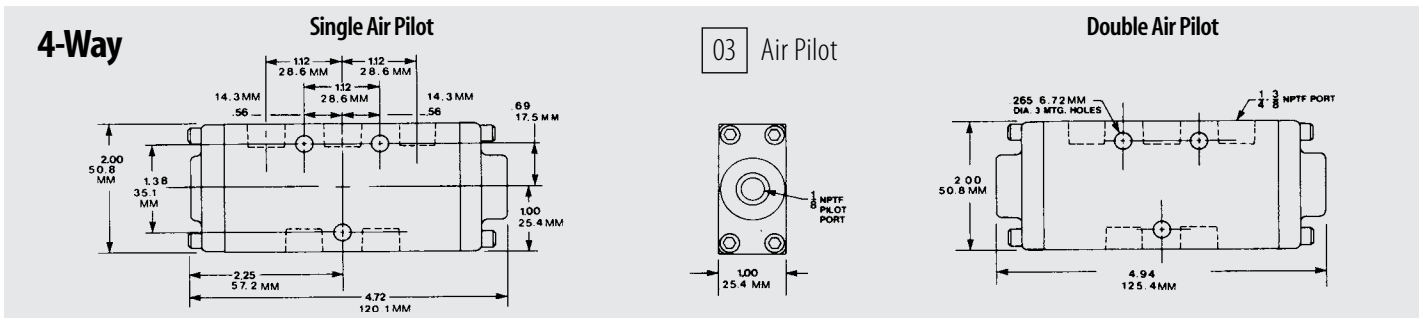
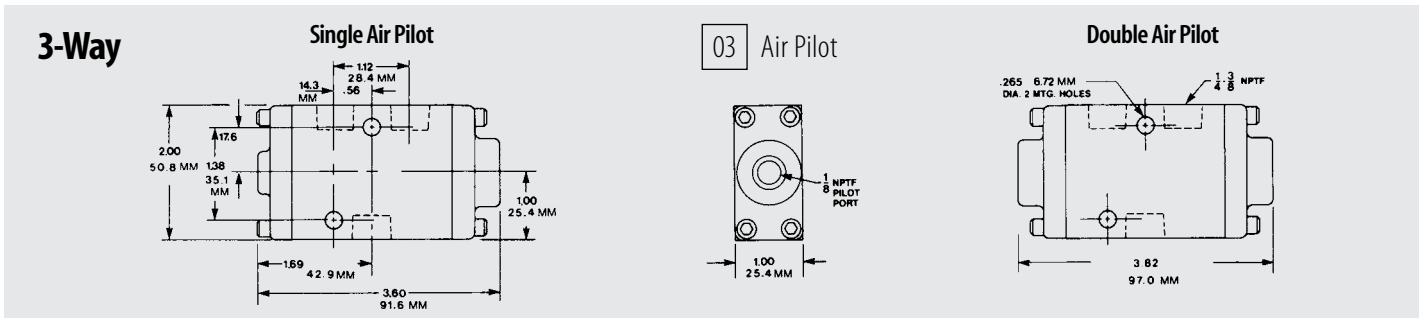

OMNI 375 SERIES VALVES

BASIC VALVE MODEL NUMBERS

| DESCRIPTION | 3-WAY | | | 4-WAY | | |
|--------------------------------|-----------|---------------|------------|-----------|---------------|------------|
| | PIPE SIZE | NUMBER | SCHEMATICS | PIPE SIZE | NUMBER | SCHEMATICS |
| Single Air Pilot Spring Return | 1/4 NPTF | 375-02-007-03 | | 1/4 NPTF | 375-02-001-03 | |
| | 3/8 NPTF | 375-02-087-03 | | 3/8 NPTF | 375-02-081-03 | |
| Double Air Pilot | 1/4 NPTF | 375-03-007-03 | | 1/4 NPTF | 375-03-001-03 | |
| | 3/8 NPTF | 375-03-087-03 | | 3/8 NPTF | 375-03-081-03 | |
| Double Air Pilot Spring Biased | 1/4 NPTF | 375-04-007-03 | | 1/4 NPTF | 375-04-001-03 | |
| | 3/8 NPTF | 375-04-087-03 | | 3/8 NPTF | 375-04-081-03 | |

This Series of 4-Way valves is available with base mounting which permits the removal or changing of a valve without disturbing the piping. The 375 Series base is machined from extruded aluminum and available with 5 threaded ports in 1/4, 3/8 or 1/2 NPTF. The valve body (004) has 5 unthreaded ports on the wide part of the valve which mate with the 5 ports on the top of the base. The body is supplied with 5 Viton O-rings and is assembled to the base.

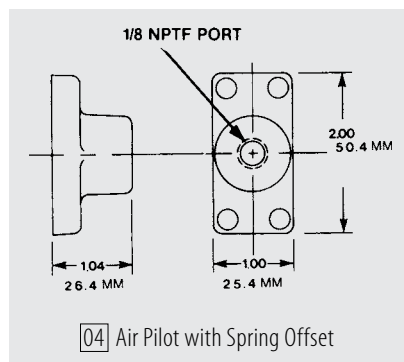
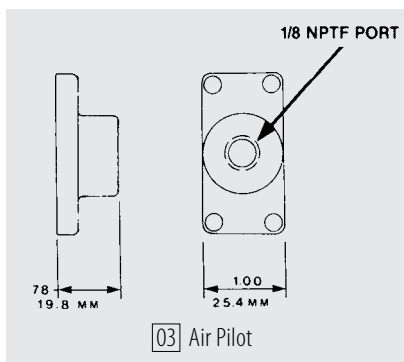
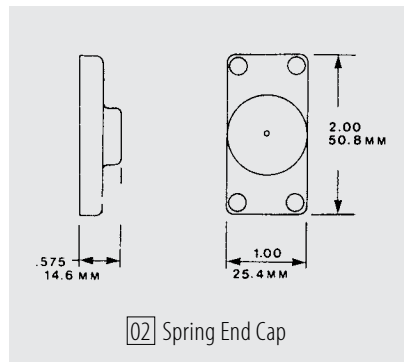
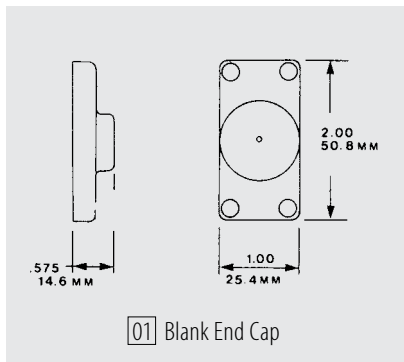

| DESCRIPTION | PIPE SIZE | NUMBER |
|--|-----------|---------------|
| Air pilot, spring return valve, base mounted, valve only | | 375-02-004-03 |
| Side Ported Base | 1/4 NPTF | 375-1401 |
| | 3/8 NPTF | 375-1402 |
| | 1/2 NPTF | 375-1405 |
| Side & Bottom Ported Base | 1/4 NPTF | 375-1168 |

Note: Valve and bases must be ordered separately.

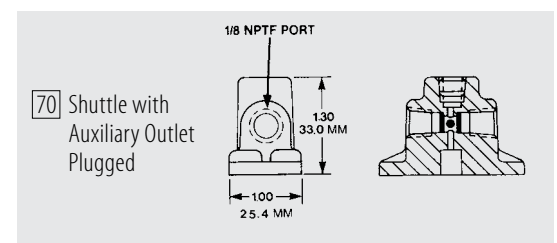
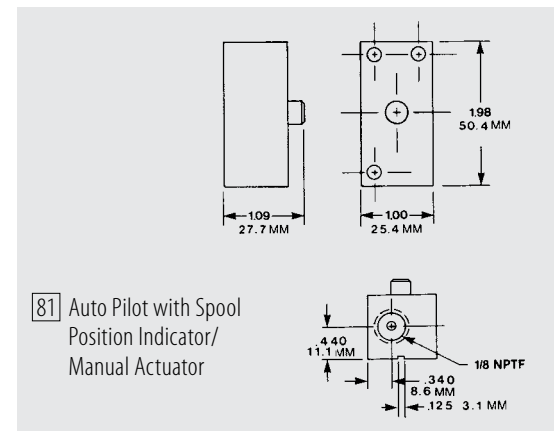

OMNI SERIES VALVES

OMNI 375 SERIES VALVES

3-WAY & 4-WAY MANUALLY OPERATED

Many applications require hand and foot actuation. The OMNI 375 3-Ways and 4-Ways offer a rugged, compact, versatile answer. Mount them in any position. Available with levers, buttons, selectors or foot pedals with spring return or detent.



4-Way Lever

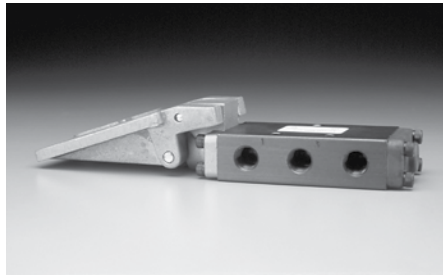

3-Way Foot Pedal



3-Way Palm Button

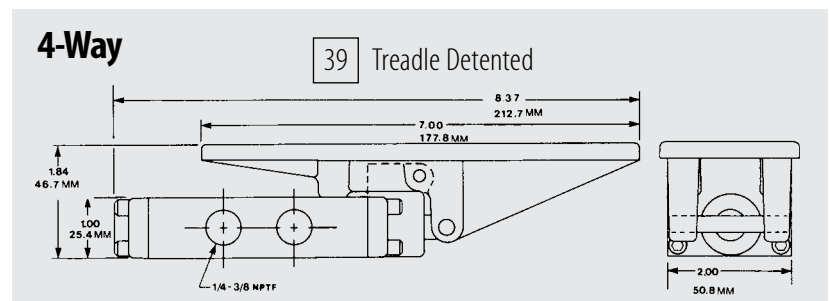
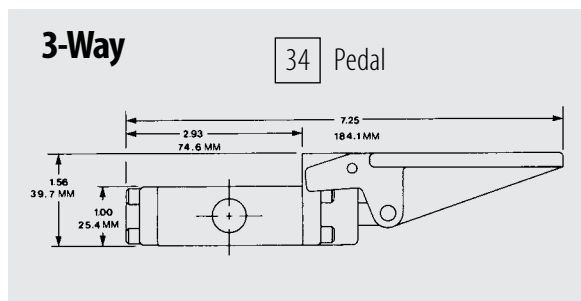
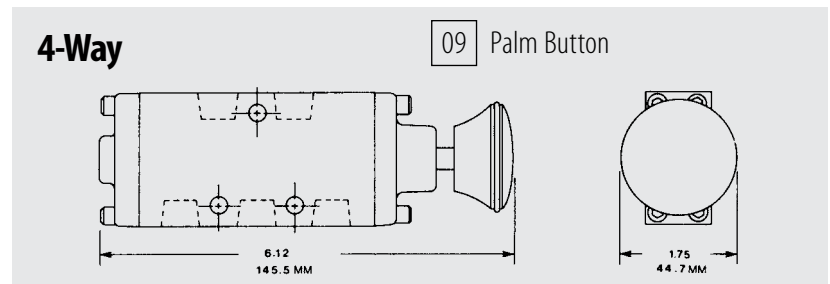
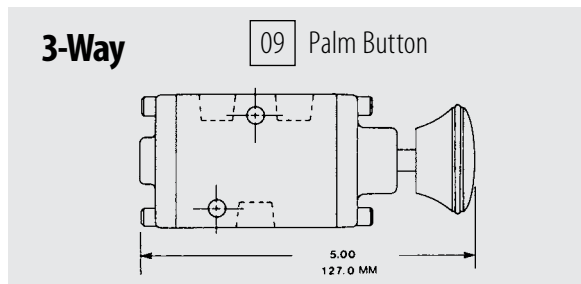
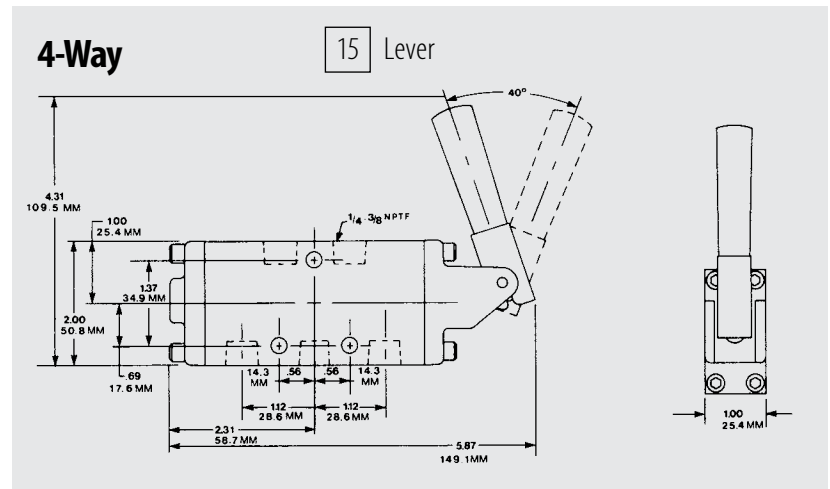
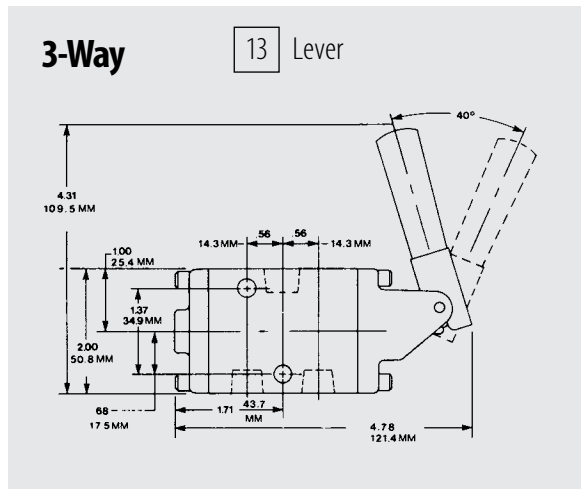

OMNI 375 SERIES VALVES

BASIC VALVE MODEL NUMBERS

| DESCRIPTION | 3-WAY | | | 4-WAY | | |
|--|-----------|---------------|------------|-----------|---------------|------------|
| | PIPE SIZE | NUMBER | SCHEMATICS | PIPE SIZE | NUMBER | SCHEMATICS |
| Palm Button Spring Return | 1/4 NPTF | 375-02-007-09 | | 1/4 NPTF | 375-02-001-09 | |
| | 3/8 NPTF | 375-02-087-09 | | 3/8 NPTF | 375-02-081-09 | |
| Parallel Side Lever with Spring Return | 1/4 NPTF | 375-02-007-13 | | 1/4 NPTF | 375-02-001-13 | |
| | 3/8 NPTF | 375-02-087-13 | | 3/8 NPTF | 375-02-081-13 | |
| Foot Operated Spring Return | 1/4 NPTF | 375-02-007-34 | | 1/4 NPTF | 375-02-001-34 | |
| | 3/8 NPTF | 375-02-087-34 | | 3/8 NPTF | 375-02-081-34 | |

This Series of 4-Way valves* is available with base mounting which permits the removal or changing of a valve without disturbing the piping. The 375 Series base is machined from extruded aluminum and available with 5 threaded ports in 1/4, 3/8 or 1/2 NPTF. The valve body (004) has 5 unthreaded ports on the wide part of the valve which mate with 5 ports on the top of the base. The body is supplied with 5 Viton O-rings and is assembled to the base.

*Because of operator overhang, not all operators available for base mount.

| DESCRIPTION | PIPE SIZE | NUMBER |
|---|-----------|---------------|
| Lever operated, spring return valve, base mounted, valve only | | 375-02-004-17 |
| Side Ported Base | 1/4 NPTF | 375-1401 |
| | 3/8 NPTF | 375-1402 |
| | 1/2 NPTF | 375-1405 |
| Side & Bottom Ported Base | 1/4 NPTF | 375-1168 |

Note: Valve and bases must be ordered separately.

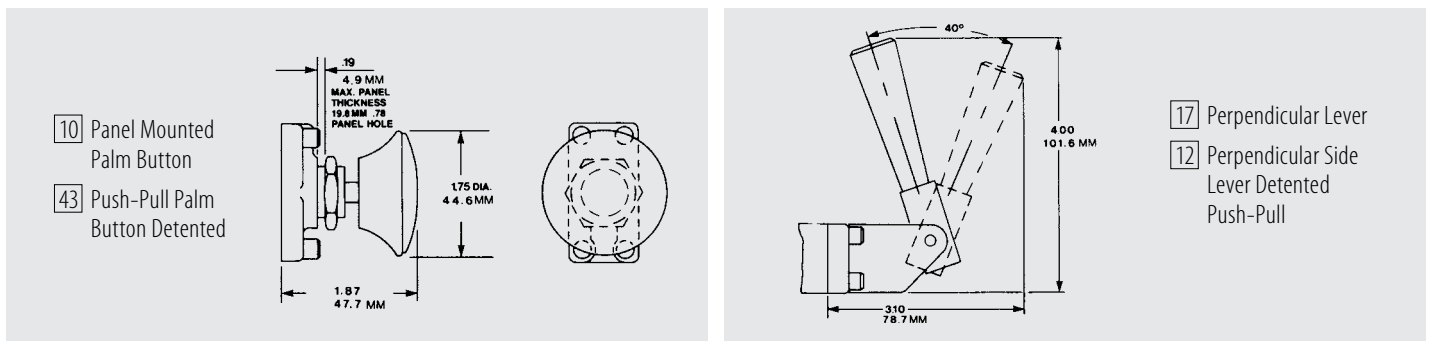
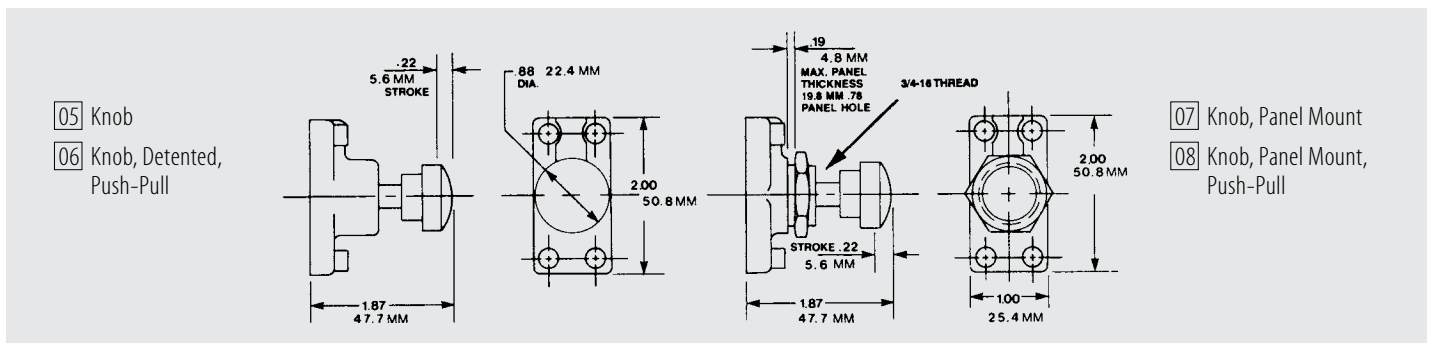

OMNI SERIES VALVES

OMNI 375 SERIES VALVES

3-WAY & 4-WAY MECHANICALLY OPERATED

Cam Operated: The compact OMNI 375 is available with roller lever or steel plunger and can be mounted in any position...375's can squeeze into tight places and deliver high flow.

Roller lever actuation: 3 styles

1. Actuation right (roller lever moved to right operates valve)
2. Actuation left (roller lever moved to left operates valve)
3. 2-Way actuation (when moved either direction operates valve)

The one-way model valve can be actuated in either direction without damage, but only the designated direction will operate valve. See diagrams below for clarification.

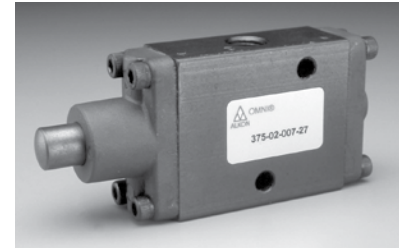

OPERATORS

| | | |
|----|----------|-------|
| 30 | Actuates | Left |
| 31 | Actuates | Right |
| 32 | Actuates | Both |

Note: 8-9 Lb. Actuation force required on roller

3-WAY ORDERING INFORMATION

| DESCRIPTION | 3-WAY | | |
|--|-----------|---------------|------------|
| | PIPE SIZE | NUMBER | SCHEMATICS |
| Parallel Roller Lever Actuation Left Spring Return | 1/4 NPTF | 375-02-007-30 | |
| | 3/8 NPTF | 375-02-087-30 | |
| Steel Plunger Spring Return | 1/4 NPTF | 375-02-007-27 | |
| | 3/8 NPTF | 375-02-087-27 | |

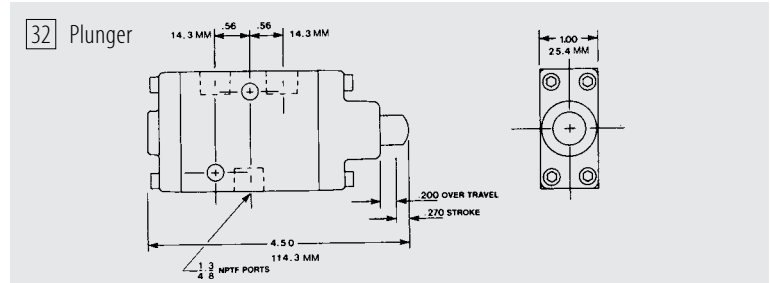
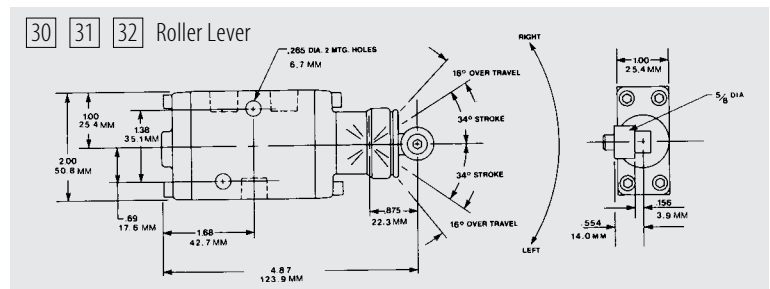

4-WAY ORDERING INFORMATION

| DESCRIPTION | 4-WAY | | |
|--|-----------|---------------|------------|
| | PIPE SIZE | NUMBER | SCHEMATICS |
| Parallel Roller Lever Actuation Left Spring Return | 1/4 NPTF | 375-02-001-30 | |
| | 3/8 NPTF | 375-02-081-30 | |
| Steel Plunger Spring Return | 1/4 NPTF | 375-02-001-27 | |
| | 3/8 NPTF | 375-02-081-27 | |

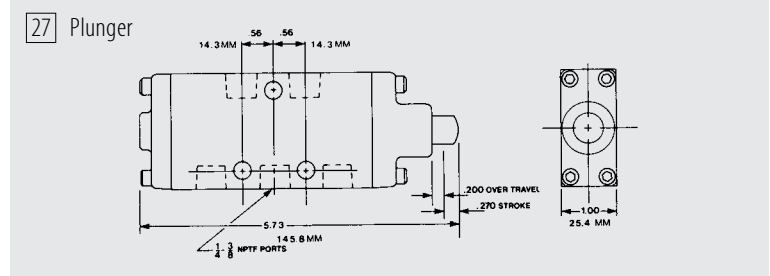
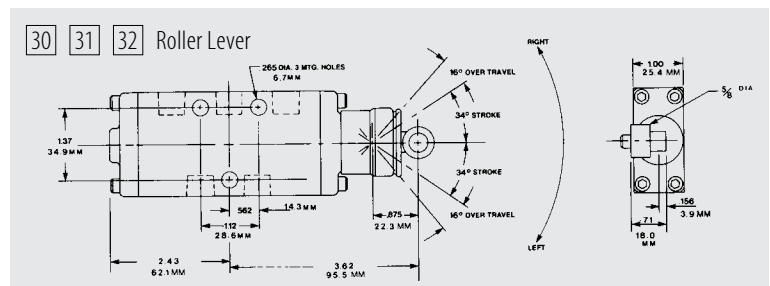

OMNI 375 SERIES VALVES

3 POSITION VALVES

OMNI 375, 3-position valves are designed and engineered to the same standards and ideals of the industry proven and accepted 2-position series. 3-position valves are simple in design, compact, rugged and high flowing. These valves offer the following features:

| AIR FLOW DATA | | |
|------------------------|----------|----------|
| PORT SIZE | 1/4 NPTF | 3/8 NPTF |
| Cv "E" Spool | 1.4 | 1.5 |
| Maxflow SCFM @ 80 PSIG | 68 | 71 |
| Cv "B" Spool | 1.4 | 1.5 |
| Maxflow SCFM @ 80 PSIG | 68 | 71 |
| Cv "P" Spool | 1.5 | 1.7 |
| Maxflow SCFM @ 80 PSIG | 71 | 79 |

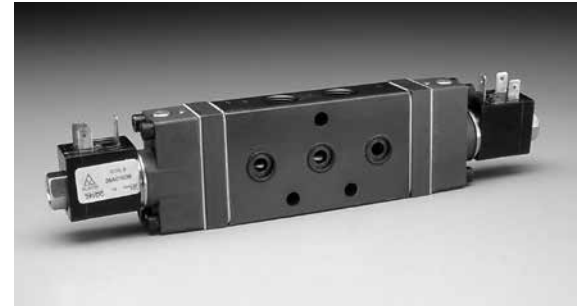
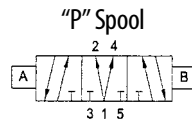
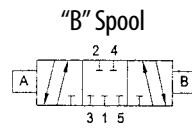
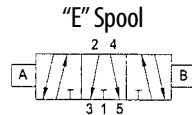

Double Solenoid Spring Centered



Lever Operated Spring Centered

ORDERING INFORMATION FOR 3-POSITION VALVES

| 375 | 33T | E01 | 33T | 1 |
|------------------------|--------------------------------------|-----------------------------------|--------------------------------------|--------------------|
| Series (375) | Operator "B" (See Listing) | Body/Base (See Listing) | Operator "A" (See Listing) | Volts/Hertz |

BODY STYLES:

| | |
|-----|--|
| B01 | 1/4 NPTF individual 4-Way blocked center |
| E01 | 1/4 NPTF individual 4-Way exhausted center |
| P01 | 1/4 NPTF individual 4-Way pressurized center |
| B81 | 3/8 NPTF individual 4-Way blocked center |
| E81 | 3/8 NPTF individual 4-Way exhausted center |
| P81 | 3/8 NPTF individual 4-Way pressurized center |
| B03 | 1/4 NPTF stacking 4-Way blocked center |
| E03 | 1/4 NPTF stacking 4-Way exhausted center |
| P03 | 1/4 NPTF stacking 4-Way pressurized center |
| B83 | 3/8 NPTF stacking 4-Way blocked center |
| E83 | 3/8 NPTF stacking 4-Way exhausted center |
| P83 | 3/8 NPTF stacking 4-Way pressurized center |
| B08 | Manifold body with blocked center |
| E08 | Manifold body with pressurized center |
| P08 | Manifold body with exhausted center |
| B04 | Base mtd. body with blocked center |
| E04 | Base mtd. body w/ pressurized center |
| P04 | Base mtd. body w/ exhausted center |

Standard Voltages:

120/60, 240/60, 24/60, 6VDC, 12VDC, 24/VDC.

Dimensional Data:

For spring centered models, add .860" to comparable 2-position valve length. For detented models, add .060" to comparable 2-position valve length.

OPERATORS:

| | |
|-----|---|
| 01T | Blank end cap for lever detented |
| 02T | Spring centering for levers |
| 03T | Spring centering air pilot |
| 13T | Spring centering parallel side or straight lever |
| 15T | Detented parallel side or straight lever |
| 17T | Spring centering perpendicular side or straight lever |
| 19T | Detented perpendicular side |
| 33T | Spring centering solenoid air pilot with conduit connection |
| 37T | Spring centering solenoid air pilot with conduit connection & manual override |
| 38T | Spring centering solenoid air pilot with conduit connection locking manual override |
| 42T | Spring centering explosion proof solenoid air pilot with conduit connection & manual override |
| 60T | Spring centering solenoid air pilot with grommet connection |
| 61T | Spring centering solenoid air pilot with grommet connection & manual override |
| 65T | Spring centering solenoid external air pilot with conduit connection & manual override |
| 67T | Spring centering solenoid air pilot with DIN connector |
| 68T | Spring centering solenoid air pilot with DIN connector & manual override |
| 82T | DIN connector, locking manual override |

OMNI SERIES VALVES

OMNI 375 SERIES VALVES

STACKING & COMMON WIREWAY ARRANGEMENTS

The OMNI 375 Series valves can be assembled into a variety of stacking arrangements which greatly reduce piping requirements and increases mounting options.

These stacks offer high flow performance in compact, space-saving packages which include:

- 2 and 3 position
- Side or bottom porting - 1/4 or 3/8 NPTF
- 4-Way, 5 ported stacks with common or dual input
- Common or individual dual exhausts
- Horizontal or vertical mounting
- Grommet, conduit, or DIN connector for electrical operators
- NEMA 4 common wireway closure
- Electronic timer



Double Solenoid Spring Centered



Double Solenoid Spring Centered

Ordering Information:

All OMNI 375 Series valve stacks and common wireway stacks are assembled with tie rods at the factory at no additional charge. The ordering procedure is very simple. First, list the quantity and model of each type of valve required. Second, determine the number of spacers required between each valve. When air pilot or DIN operated valves are used, spacers are not required. When manually operated valves are used, allow one spacer between each valve, but not between a valve and end plate. When solenoid operated valves are used (with or without manual override) allow one spacer between each valve, but not between a valve and end plate. For operators 42, 66, or 74 consult factory. Third, specify the type of end plate assembly required (side or bottom ported, 1/4 or 3/8 NPTF, horizontal or vertical). Fourth, for common wireway stacks, specify model enclosure. In most cases where a 3-Way valve function is required in a stack, a pipe plug is used to block one of the cylinder ports.

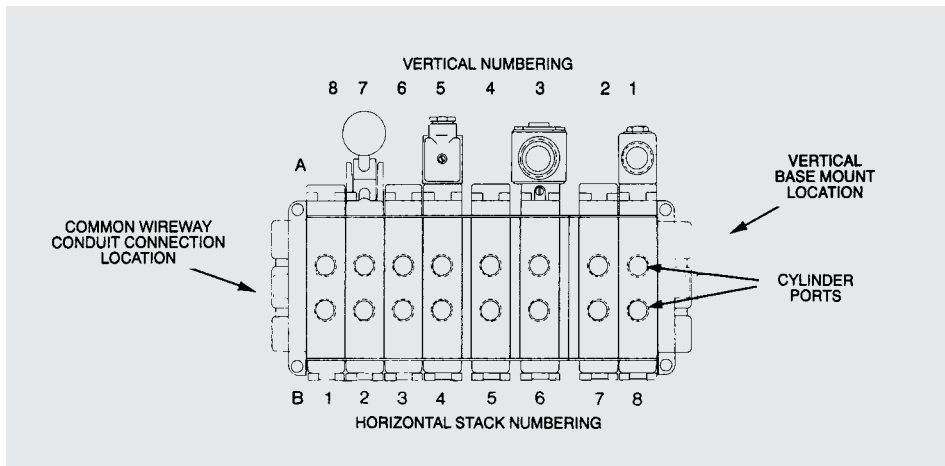

Example for ordering two, 375 Series stacks with common wireway:

- (2) 375 Series common wireway stack consisting of:
 - (4) 375-02-009-68C 120/60 with lights
 - (1) 375-1230 side ported 1/4 NPTF end plate assembly
 - (1) 37-1122 NEMA 4 enclosure

Example for ordering two, 375 Series stacks:

- (2) 375 Series stack consisting of:
 - (3) 375-37-003-37 120/60
 - (2) 375-02-003-37 120/60
 - (4) 375-1240 Spacer Plates
 - (1) 375-1231 bottom ported 3/8 NPTF end plate assembly

NOTE: When ordering, if more than one model number valve is to be stacked, specify valve position by numbering valves from left to right while facing the "B" end operators. If a vertical mounting plate is used, number valves starting from vertical plate.

OMNI 375 SERIES VALVES

Order Numbers for Common Wireway NEMA 4 Enclosure

| DESCRIPTION | MODEL |
|--|-----------------|
| 2 valve, single solenoid enclosure | 37-1200 |
| 2 thru 4 valves, double solenoid enclosure | 37-1123 |
| 5 thru 6 valves, single solenoid enclosure | 37-1124 |
| 5 thru 6 valves, double solenoid enclosure | 37-1125 |
| 7 thru 9 valves, single solenoid enclosure | 37-1127 |
| 7 thru 9 valves, double solenoid enclosure | 37-1128 |
| 10 + valves | Consult factory |

If any one valve in stack is double solenoid, you must order double solenoid enclosure.

Order Number For Common Wireway & Standard Stack End Plate Assemblies

| DESCRIPTION | MODEL |
|--|--------------|
| Vertical mount assembly (with 3/8" NPTF ports) | 375-1213-3/8 |
| Horizontal mount assembly (specify 1/4" or 3/8" NPTF) side ported plates | 375-1230 |
| Horizontal mount assembly (specify 1/4" or 3/8" NPTF) bottom ported plates (for stacks only) | 375-1231 |
| Spacer plate (for stacks only) | 375-1240 |

Common Wireway (NEMA 4)

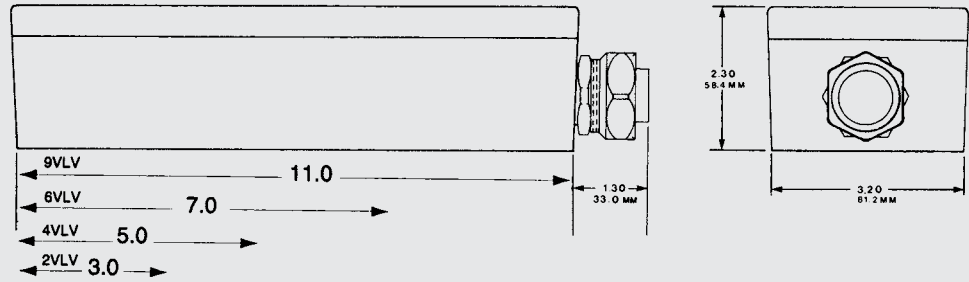

Body Options

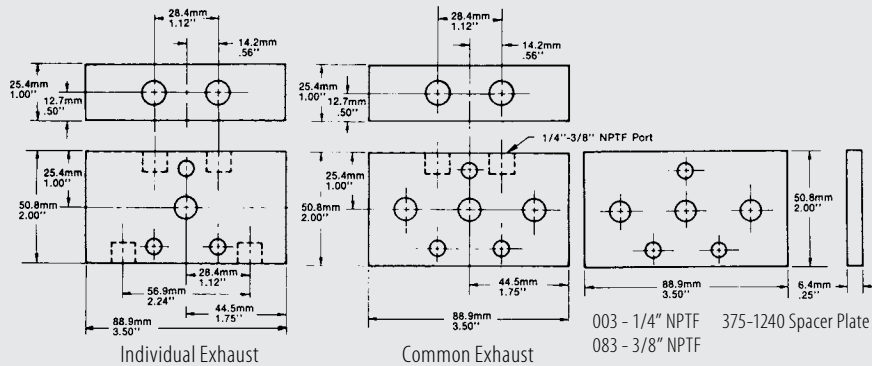

End Plate Assemblies

Note: End Plate Assemblies consist of the following:
2 end plates, 3 tie-rods and all nuts and O-rings needed.

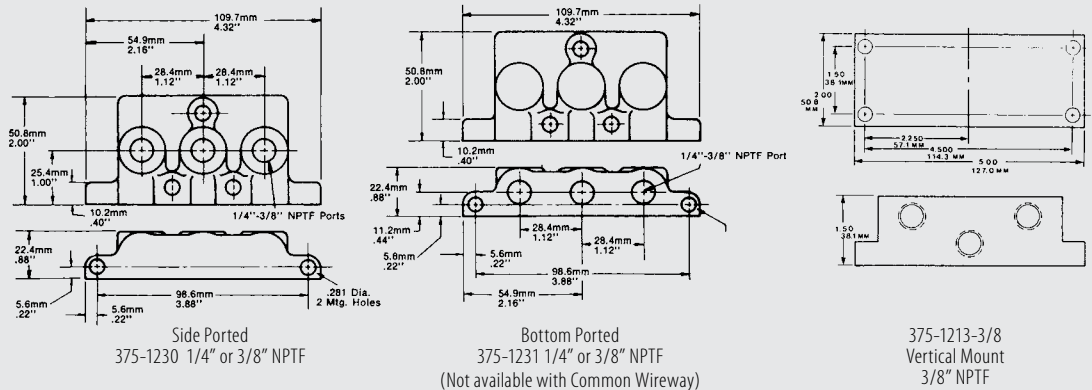

OMNI SERIES VALVES

OMNI 375 SERIES VALVES

MANIFOLD MOUNTED VALVES

The highly reliable standard OMNI 375 valve can also be manifold mounted. This Alkon engineering advancement requires a minimum of piping while providing multiple mounting arrangements, compact rugged design and extremely high air flow. Simple in design, yet sophisticated in performance. The manifold mounted OMNI 375 offers these additional features:

- Complete range of solenoid connectors
- Solenoid, manual or air operators
- Tapped 1/4 or 3/8 NPTF, machined from rugged and extruded anodized aluminum
- SCFM 103 @ 80 PSI
- Cv of 2.2
- All piping arrangements in manifold
- Dual pressure manifolding
- Pin locators insure exact positioning of valves on manifold
- Valves can be easily and quickly added, removed or isolated for changing circuit requirements

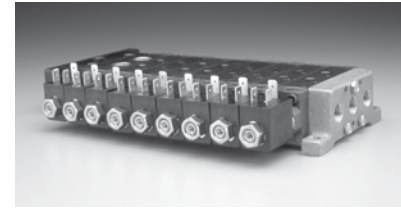

Manifold Mounted Valves

Each Alkon manifold is designed to accept two 4-Way 5-ported OMNI valves. For a 3-Way application, one of the cylinder ports in the manifold must be plugged.

Where the manifold is to be mounted vertically, a base plate with a 3/8 NPTF supply port is available (see illustration). Main air supply to manifold is piped directly to 3/8 NPTF end plates. Mounting holes in end plates offer added versatility.

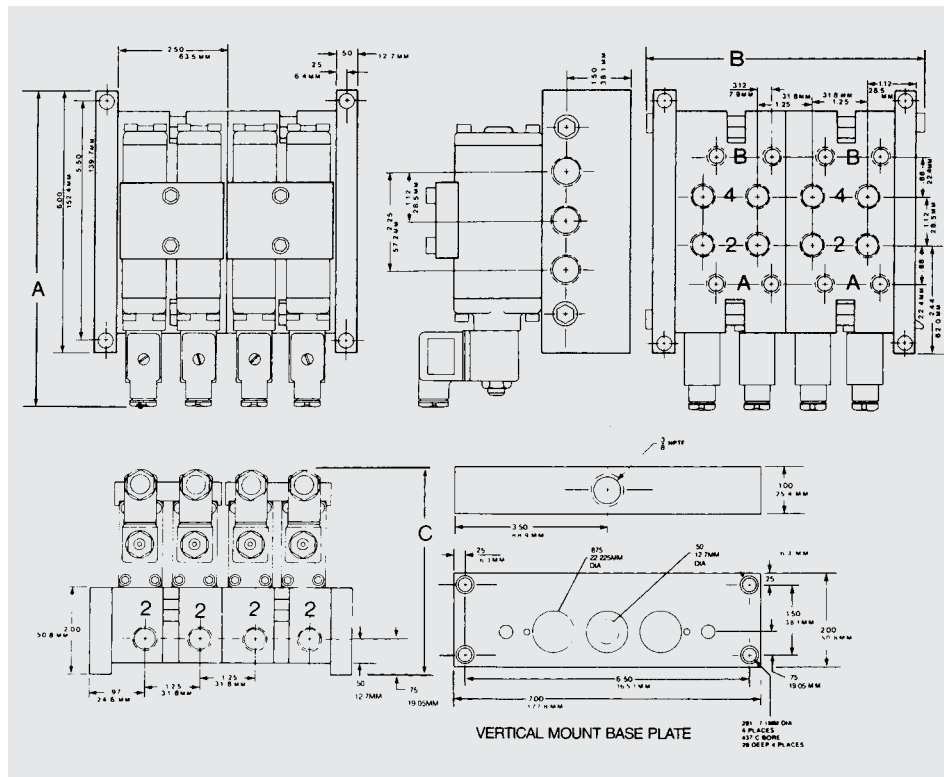

| DIMENSION "A" | INCH | MM |
|---|------|--------|
| Single Solenoid, Spring Return | 7.25 | 184.15 |
| Double Solenoid, Momentary | 9.40 | 338.76 |
| Air Pilot, Spring Return | 6.00 | 152.4 |
| Double Air Pilot, Momentary | 6.00 | 152.4 |
| DIMENSION "B" | | |
| Two Station | 3.90 | 99.1 |
| Three Station | 6.40 | 162.6 |
| Four Station | 6.40 | 162.6 |
| NOTE: For more than four stations, add 2.5 inches for each two station manifold. | | |
| DIMENSION "C" | | |
| Solenoid Operated with Conduit Connection | 4.70 | 119.4 |
| Air Pilot | 4.44 | 112.8 |

OMNI 375 SERIES VALVES

MANIFOLD VALVES ORDERING INFORMATION

To order an even number of valves, specify the required number of manifolds and valves.

For odd number of valves, order a valve blank for one of the manifold stations or an extra valve for emergency requirements.

| ORDER NUMBERS FOR MANIFOLD ONLY | |
|--|----------|
| DESCRIPTION | MODEL |
| Two station manifold 1/4 NPTF ports, 1/8 NPTF pilot ports (for pilot application) complete with O-rings and tie bolts and tie down clamps | 375-1164 |
| Two station manifold 3/8 NPTF ports, 1/8 NPTF pilot ports (for pilot application) complete with O-rings and tie bolts and tie down clamps | 375-1166 |
| Right end plate (facing "B" end of manifold) complete with O-rings and hex head bolts 3/8 NPTF | 375-1199 |
| Left end plate (facing "B" end of manifold) complete with hex lock nuts, no O-rings* 3/8 NPTF | 375-1200 |
| Base Plate for vertical mounting of manifold 3/8 NPTF supply port. Complete with lock nuts and O-rings. (For other end of manifold use right end plate.) | 375-1300 |
| Tie-Down Clamp | 375-1035 |
| Manifold with Dual Pressure 3/8 NPTF ports | 375-1203 |
| Two Station Manifold, 3/8 NPTF ports, complete, for use with 4-2 operators | 375-1591 |

Ordering Sequence for Manifold and Valves

| QTY. | DESCRIPTION |
|------|--|
| 1 | 375 Series Manifold Assembly consisting of: |
| | (4) 375-1164 manifold 1/4 NPTF |
| | (7) 375-02M-008-68M valves 120/60 |
| | (1) 375-000 Valve Blank |
| | (1) 375-1199 Right End Plate |
| | (1) 375-1200 Left End Plate |

Note: If specific valve locations are required, please specify. Blocking discs available to facilitate dual pressure, #32A01032.

ORDERING INFORMATION FOR 3-POSITION VALVES

| 375 | 02M | 008 | 33M | 120/60 |
|------------------------|--------------------------------------|-----------------------------------|--------------------------------------|--------------------|
| Series (375) | Operator "B" (See Listing) | Body/Base (See Listing) | Operator "A" (See Listing) | Volts/Hertz |

| BODY | |
|------|--|
| 008 | 5 Ported 4-Way |
| 000 | Valve Blank (order as 375-000 for odd number valves) |



















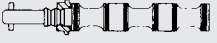



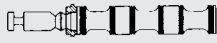

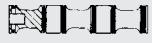
OPERATORS:

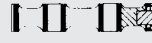
| | |
|-----|---|
| 01 | Blank end cap |
| 02 | Spring return |
| 03M | Air pilot |
| 04M | Air pilot spring offset |
| 13 | Lever, parallel |
| 15 | Lever, parallel, detented |
| 33 | Solenoid air pilot with conduit connection |
| 37 | Solenoid air pilot with conduit connection and manual override |
| 38 | Solenoid air pilot with conduit connection and locking manual override |
| 42 | Solenoid with explosion-proof housing |
| 60 | Solenoid air pilot with grommet connection |
| 61 | Solenoid air pilot with grommet connection and manual override |
| 65M | Solenoid external air pilot with conduit connection and manual override |
| 67 | Solenoid air pilot with DIN |
| 68 | Solenoid air pilot with DIN connector and manual override |
| 81M | Air pilot with spool position indicator / manual actuator |

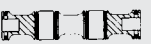
OMNI SERIES VALVES

OMNI 375 SERIES VALVES

REPLACEMENT PARTS

| OPERATOR NO. | SPOOL REPLACEMENT* |
|----------------------|--|
| 06, 08, 43 |  3-Way 2 Position 90A20095  4-Way 2 Position 90A20106 |
| 13, 17 |  3-Way 2 Position 90A20078  4-Way 2 Position 90A20075  3 Position B 90A20182  3 Position E 90A20183  3 Position P 90A20184 |
| 15, 19 |  3-Way 2 Position 90A20112  4-Way 2 Position 90A20113  3 Position B 90A20185  3 Position E 90A20186  3 Position P 90A20187 |
| Foot Pedal 34, 39 |  3-Way 2 Position 90A20116  4-Way 2 Position 90A20117 |
| 42 | <div style="display: flex; justify-content: space-between;"> <div style="width: 45%;"> <p>3-Way 2 Position</p>  Single 90A20075  Double 90A20132 </div> <div style="width: 50%;"> <p>4-Way 2 Position</p>  Single Solenoid 90A20188  Double Solenoid 90A20189  3 Position B 90A20190  3 Position E 90A20078  3 Position P 90A20205 </div> </div> |
| 27, 30, 31, 32 |  3-Way 2 Position 90A20201  4-Way 2 Position 90A20127 |
| All Others |  3 Position B 90A20175  3 Position E 90A20176  3 Position P 90A20177  3-Way 2 Position 90A20078  4-Way 2 Position 90A20075 |

*Material: Aluminum is standard. Derlin available on some operators. Consult factory.

COIL REPLACEMENT

| DESCRIPTION | MOLDED |
|--|----------|
| Coil with conduit housing 33, 37, 38, 65 operators, 7 watt | 26A01017 |
| Coil with grommet housing 59, 60, 61 operators, 7 watt | 26A01033 |
| Coil for explosion proof housing 42 operators, 7 watt | 26A01043 |
| Coil for DIN connector, 8.5 watt | 26A01039 |

When ordering coil, give part no. and voltage. Standard voltages are: 120/60, 240/60, 6VDC, 12VDC, 24VDC. For other voltages consult factory.

Torque Settings for Coil Hold Down Nuts are:

- 20-25 in-lbs. for Canned type operators
- 20-25 in-lbs. for DIN operators
- 55 in-lbs. for operators 42

STAINLESS STEEL 316 SERIES

ORDERING INFORMATION FOR STAINLESS STEEL 316 SERIES

| 316 | 02 | 001 | 38 | 1 |
|------------------------|--------------------------------------|--|--------------------------------------|--------------------|
| Series (316) | Operator "B" (See Listing) | Body/Base (See Listing) | Operator "A" (See Listing) | Volts/Hertz |
| | | 001 = 1/4 NPTF ported (375 size) individual 4-Way | | 1 = 120/60 AC* |
| | | | | 5 = 24 VDC* |

OPERATORS:

| | |
|----|--|
| 01 | Blank end cap |
| 02 | Spring end cap |
| 03 | Air pilot |
| 15 | Lever detented parallel push-pull |
| 38 | Conduit connection locking manual override |
| 41 | Explosion-proof conduit connection, locking manual override, stainless steel |

*Denotes standard voltages.

Ordering Procedure for Stainless Series 316:

- 1. Series Designation** – 316 identifies 316 series stainless.
- 2. "B" Operator** – This is the secondary operator. The secondary operator returns the spool.
- 3. Body Style** – 1/8" body available in 4-Way only, but can be plugged to make 3-Way or 2-Way.
- 4. "A" Operator** – This is the primary operator. The primary operator moves the spool away from the start position.
- 5.** Specify voltages or any other special conditions.



STAINLESS STEEL 316 SERIES

ENGINEERING & TECHNICAL DATA

MATERIAL

- 316 Series – Metal components are 316 stainless steel excluding standard solenoid operator.

BODY STYLE

- 1/4 NPTF ported – 3-Way bodies and 4-Way bodies.

CONFIGURATIONS

- Solenoid, air, and manual actuators, In-line.

LUBRICATION

- All valves are pre-lubricated and will operate dry (with no additional lubrication). However, a lubricated system will greatly extend the service life of any valve.

“THIN-LIP” SEAL & SPOOL

- PTFE loaded Viton seals provide millions of trouble-free cycles.
- Minimal breakout friction.
- Unique wiping action eliminates contaminate buildup in bore.
- Reduces spool hang-up due to compressor or oil varnishing.
- Operates effectively in lubricated or non-lubricated systems.

SOLENOID HOUSING CLASSIFICATIONS

Conduit and Grommet Housings with Molded Coils Meet:

- NEMA 1 General Purpose = Indoors
- NEMA 2 Dripproof = Indoors
- NEMA 3 Driptight = Indoors
- NEMA 4* Watertight & Dusttight = Indoors & Outdoors
- NEMA 6* Submersible, Watertight, Dusttight & Sleet-Ice Resistant = Indoors & Outdoors

*Specify “Potted” Coil Option to meet NEMA 4 & 6.

Explosion Proof Housings Meet:

- NEMA 7C, 7D & CSA Class I = Groups C & D = Explosion Proof
- NEMA 8C, 8D & CSA Class I = Groups C & D = Explosion Proof
- NEMA 9E, 9F, 9G & CSA Class II = Groups E, F & G = Explosion Proof

VALVE OPERATING SPECIFICATIONS

| | |
|---------------------------|---|
| MEDIA: | Air & Gas |
| PRESSURE RANGE: | Main Supply: 40 - 150 psig (standard) Vacuum to 40 psig is available |
| | Sol. Pilot Air: Minimum 40 psig to 150 psig and not less than the main air supply. For lower pilot pressure consult factory. |
| TEMPERATURE RANGE: | 0°C to 85°C 32°F to 180° F |

For other temperatures consult factory.

FLOW DATA

| PORT | Cv | SCFM at 80 psi |
|---------|-----|----------------|
| 1/4 NPT | 2.2 | 104 |

REPLACEMENT PARTS / SPOOL REPLACEMENT

| AIR & SOLENOID | | S.S. |
|----------------|-----------------------|----------|
| 1/4 NPTF | Single & Double Pilot | 90A20295 |

SOLENOID DATA

| STANDARD VOLTAGES | CURRENT (AMPS) | |
|-------------------|----------------|---------|
| | INRUSH | HOLDING |
| 120/60AC | .11 | .07 |
| 24VDC | .29 | .29 |

Other AC and DC voltages available special order.

Note: 120/60Hz can be connected to 110/50Hz.

Molded epoxy coils standard.

Explosion-proof solenoids available.

COIL REPLACEMENT

| DESCRIPTION | | MODEL |
|----------------------------------|--------------|----------|
| Coil with conduit housing | 38 operators | 26A01017 |
| Coil for explosion-proof housing | 41 operators | 26A01043 |

When ordering coil give part no. and voltage.

Standard voltages are; 120/60, 24VDC. For other voltages consult factory.



www.alkoncorp.com

Phone 419.333.7000

Fax 419.355.9211

728 Graham Drive

Fremont, OH 43420